

***KTM* POWERPARTS** **INFORMATION**

SUPPLEMENTARY HEADLIGHT KIT



60714910033

04.2017
3.213.622



KTM Sportmotorcycle GmbH
5230 Mattighofen, Austria
www.ktm.com



3 DEUTSCH

Wir freuen uns, dass Sie sich für dieses Produkt entschieden haben.

Unser hochwertiges Qualitätsprodukt ist rennerprobt und wurde speziell für sportliche Herausforderungen entwickelt. Eine korrekte Montage des Produktes ist unerlässlich, um ein Maximum an Sicherheit und Funktionalität gewährleisten zu können. Bitte befolgen Sie daher die Montageanleitung oder wenden Sie sich an Ihren autorisierten Fachhändler.

Für falsche Montage oder Verwendung dieses Produktes kann der (Quasi-)Hersteller bzw. Lieferant nicht zur Verantwortung gezogen werden.
Vielen Dank.

9 ENGLISH

Thank you for choosing this product.

Our high quality product has been tested under racing conditions and was developed specifically for use in sports activities. Correct installation of the product is essential to ensure that a maximum degree of safety and functionality is achieved. Therefore, please follow the installation instructions or contact your authorized dealer.

The (quasi) manufacturer or supplier cannot be held responsible for products that are incorrectly mounted or inappropriately used.
Thank you.

15 ITALIANO

Grazie per aver scelto questo prodotto.

Questo nostro prodotto di pregiata qualità è collaudato nelle competizioni ed è stato sviluppato specificamente per gare sportive. Il montaggio corretto del prodotto è fondamentale per garantirne la massima sicurezza e funzionalità. Rispetti quindi le istruzioni di montaggio o rivolgerti al proprio concessionario autorizzato.

Il produttore (detentore del marchio)/fornitore non può essere considerato responsabile per un montaggio o impiego errato del presente prodotto.
Vi ringraziamo per l'attenzione!

21 FRANÇAIS

Merci d'avoir porté votre choix sur ce produit.

Notre produit de haute qualité est éprouvé pour les compétitions et a été conçu spécialement pour un usage sportif. Un montage approprié du produit est indispensable pour garantir une sécurité et une fonctionnalité maximales du véhicule. C'est pourquoi nous vous invitons à suivre scrupuleusement le manuel de montage ou à vous adresser à votre revendeur agréé.

En cas de montage ou d'utilisation non conformes de ce produit, le (quasi) constructeur ou le fournisseur déclinent toute responsabilité.
Merci !

27 ESPAÑOL

Le agradecemos que se haya decidido por este producto.

Este producto de alta calidad está probado para la competición y se ha desarrollado específicamente para las exigencias de este deporte. Para poder garantizar los máximos niveles de seguridad y funcionalidad, es imprescindible que el producto se monte correctamente. Por este motivo, es muy importante que siga las instrucciones del manual de montaje o que se ponga en contacto con su concesionario autorizado.

El (cuasi) fabricante y el proveedor de este producto no se harán responsables del montaje y el uso incorrectos.
¡Muchas gracias!

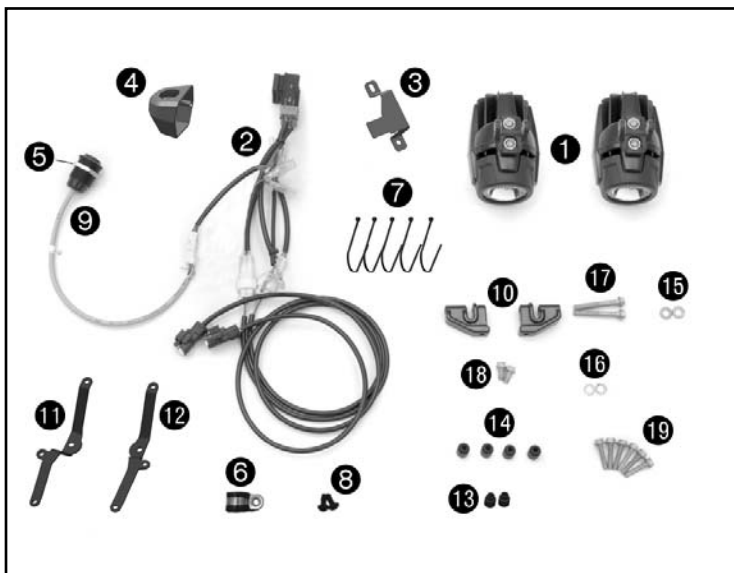

Lieferumfang

- 2x Nebelscheinwerfer ①
- 1x Kabelstrang ②
- 1x Halblech Relais ③
- 1x Schaltergehäuse ④
- 1x Mutter für Schalter ⑤
- 1x Schelle ⑥
- 5x Kabelbinder ⑦
- 2x Schraube ⑧
- 1x Schalter ⑨
- 1x Montagekit Zusatzscheinwerfer
 - 2x Gelenkstück ⑩
 - 1x Halblech Scheinwerfer links ⑪
 - 1x Halblech Scheinwerfer rechts ⑫
 - 2x Buchse kurz ⑬
 - 4x Buchse lang ⑭
 - 2x Unterlegscheibe ⑮
 - 2x Nordlockscheibe ⑯
 - 2x Bundschraube M6x45 ⑰
 - 2x Bundschraube M6x12 ⑱
 - 6x Bundschraube M6x25 ⑲

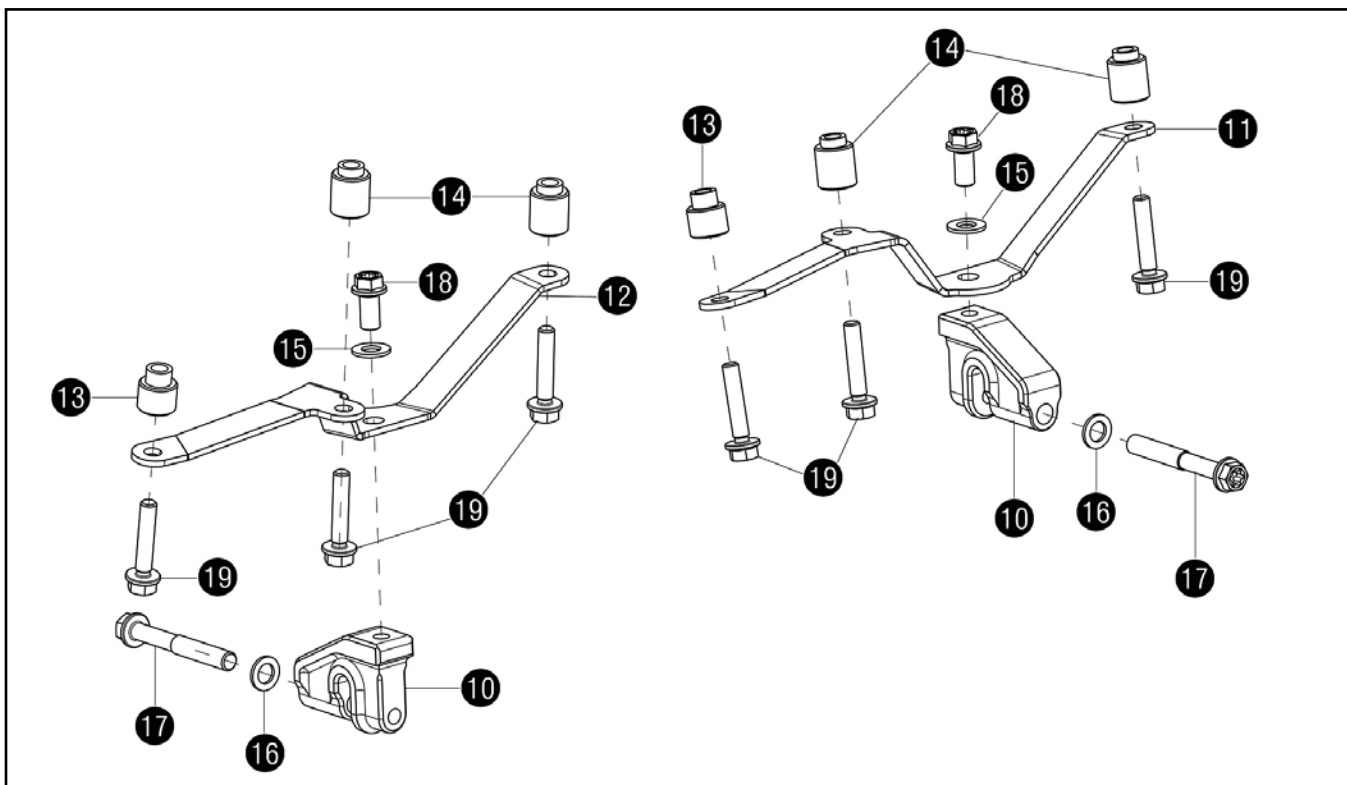

 Alle Arbeiten, die mit diesem Symbol gekennzeichnet sind, erfordern Fachkenntnisse und technisches Verständnis. Lassen Sie diese Arbeiten, im Interesse Ihrer eigenen Sicherheit, in einer autorisierten KTM- Fachwerkstatt durchführen! Dort wird Ihr Motorrad von speziell geschulten Fachkräften mit dem erforderlichen Spezialwerkzeug optimal betreut.

Vorarbeit

- Sitzbank abnehmen (s. Bedienungsanleitung).
- Seitenverkleidung vorne ausbauen (s. Bedienungsanleitung).
- Maskenspoiler ausbauen (s. Bedienungsanleitung).
- Tankabdeckung ausbauen (s. Bedienungsanleitung).
- Scheinwerfer ausbauen (s. Reparaturanleitung). 

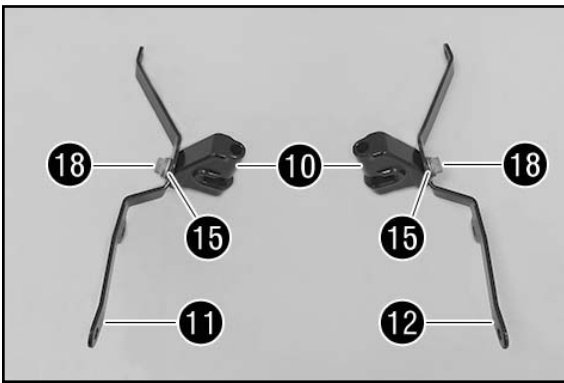

Vormontage

- Halteblech links **11** und rechts **12** auf Gelenkstücke **10** (alles Lieferumfang) positionieren.
- Schrauben **18** mit Unterlegscheiben **15** montieren und festziehen.

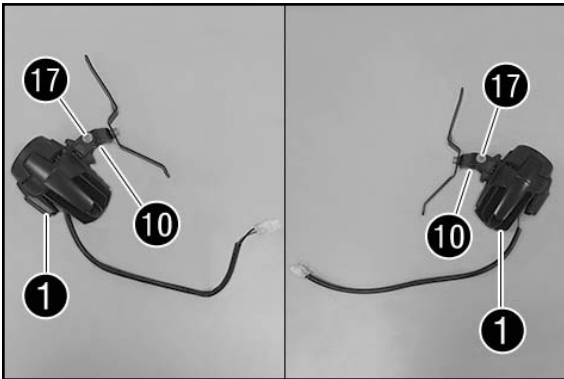

- Nebelscheinwerfer **1** (Lieferumfang) auf die Gelenkstücke **10** positionieren.
- Schrauben **17** mit Nordlockscheiben **16** (alles Lieferumfang) montieren und festziehen.

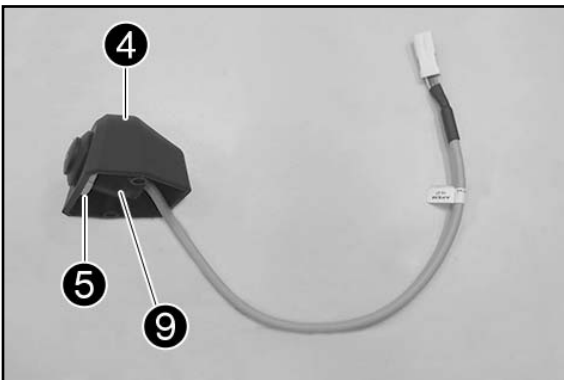

- Schalter **9** in Schaltergehäuse **4** (alles Lieferumfang) montieren.
- Mutter **5** des Schalters (Lieferumfang) montieren und festziehen.

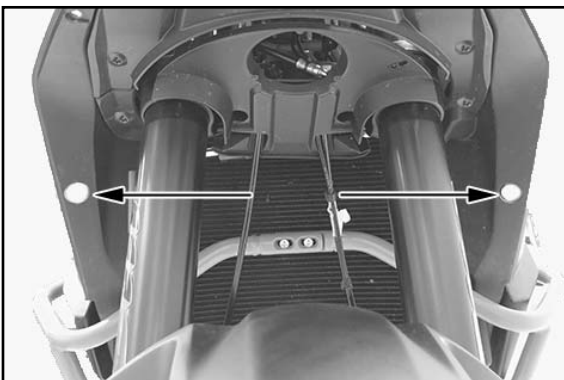

Montage

- Montageloch wie dargestellt mit geeignetem Werkzeug beidseitig in die Innenverkleidung bohren (Ø 22 mm).

! VORSICHT
 Beim Bohren darauf achten, dass keine Bauteile beschädigt werden!

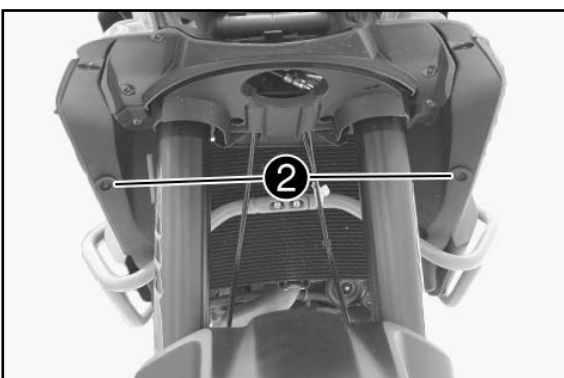

- Kabeltüllen **2** (Lieferumfang Kabelstrang) in die Bohrungen positionieren.

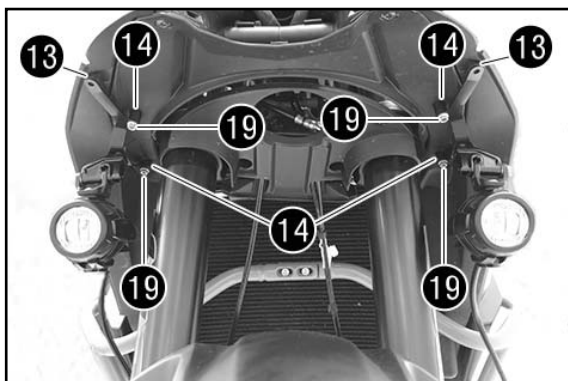

- Halteblech mit Nebelscheinwerfer links 11 und rechts 12 positionieren.
- Kurze Buchsen 13 (Lieferumfang) montieren.
- Schrauben 19 mit langen Buchsen 14 (alles Lieferumfang) montieren und mit 3,5 Nm festziehen.

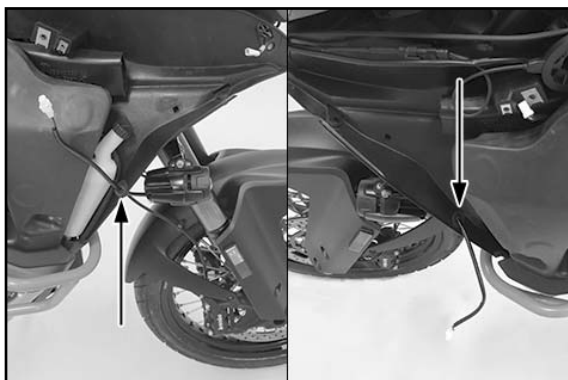

- Kabel der Nebelscheinwerfer beidseitig durch die Kabeltüllen verlegen.

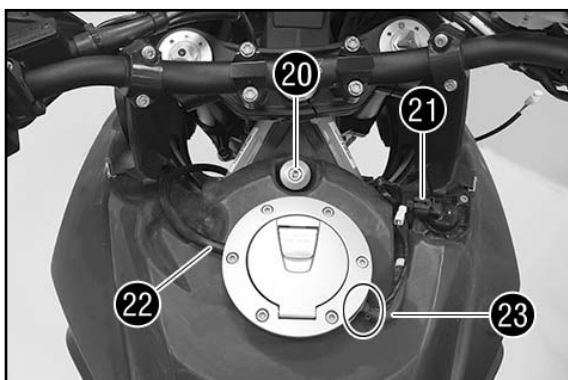

Kabelstrang verlegen

- Schraube 20 mit Lagerhülse und Gummibuchsen entfernen.
- Stecker 21 abstecken.
- Entlüftungsschlauch 22 abziehen.
- Kabelbinder entfernen.
- Entlüftungsschlauch 23 abziehen.



- Schrauben 24 mit Buchsen entfernen.
- Tank leicht anheben und nach hinten ziehen.

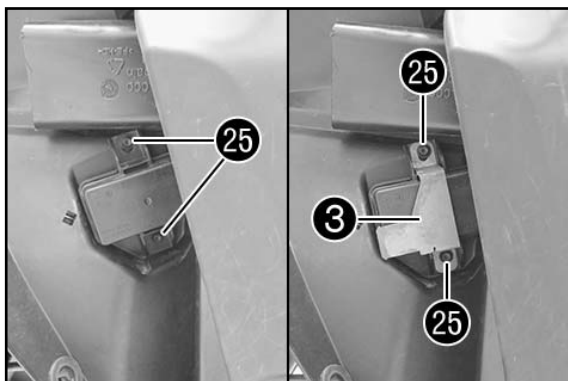

- Schrauben 25 entfernen.
- Halteblech 3 (Lieferumfang) mit Schrauben 25 montieren und festziehen.

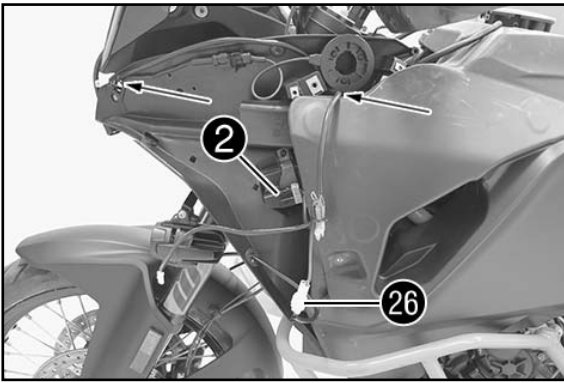

- Kabelstrang (Lieferumfang) wie dargestellt spannungsfrei in Richtung Scheinwerfer verlegen.
- Relais ② (Lieferumfang Kabelstrang) am Halteblech ③ montieren.
- Steckerverbindung ②⑥ zusammenstecken.

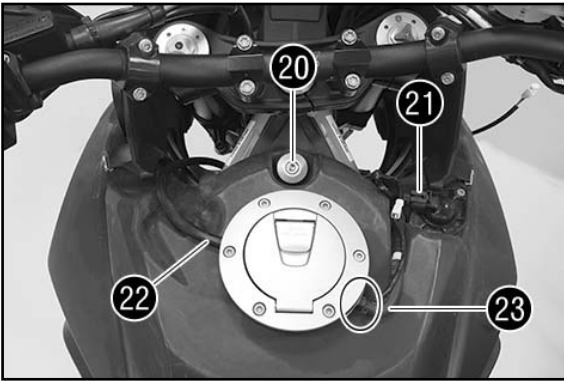

- Kraftstofftank positionieren.
- Schraube ⑳ mit Lagerhülse und Gummibuchsen montieren und mit 15 Nm festziehen.
- Stecker ㉑ anstecken.
- Entlüftungsschläuche ㉒ und ㉓ montieren.
- Kabelbinder montieren.

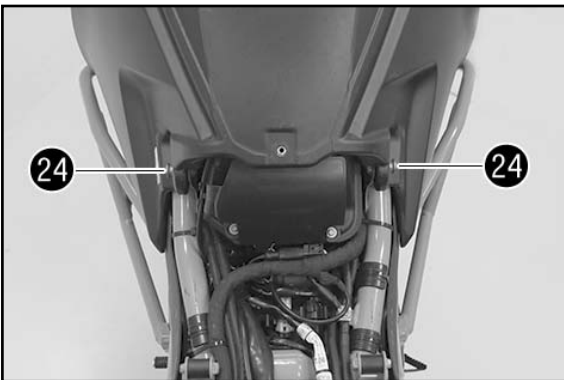

- Schrauben ㉔ mit Buchsen beidseitig montieren und mit 10 Nm festziehen.

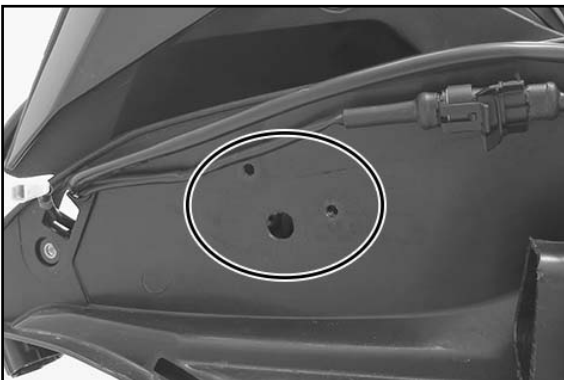

Schalter montieren

- Montagelöcher mit geeignetem Werkzeug bohren (Ø 22 mm und Ø 5 mm).

HINWEIS

Die Positionen sind auf der Verkleidung markiert.

! VORSICHT

Beim Bohren darauf achten, dass keine Bauteile beschädigt werden!

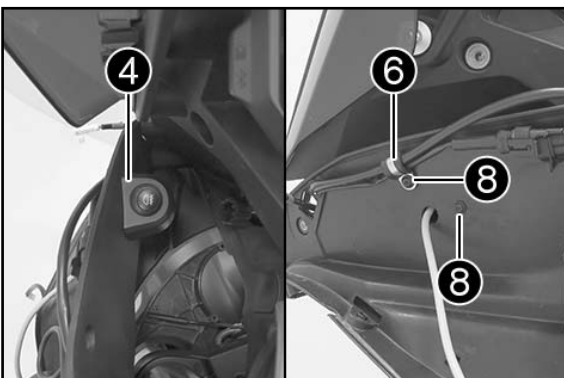

- Schaltergehäuse ④ mit Schalter (Lieferumfang) positionieren.
- Kabel durch die Bohrung verlegen.
- Schelle ⑥ (Lieferumfang) positionieren.
- Schrauben ⑧ (Lieferumfang) montieren und festziehen.



- Steckerverbindung 27 zusammenstecken.
- Kabel spannungsfrei verlegen.

! VORSICHT

Sicherstellen, dass die Kabel nicht geknickt oder geklemmt werden können!

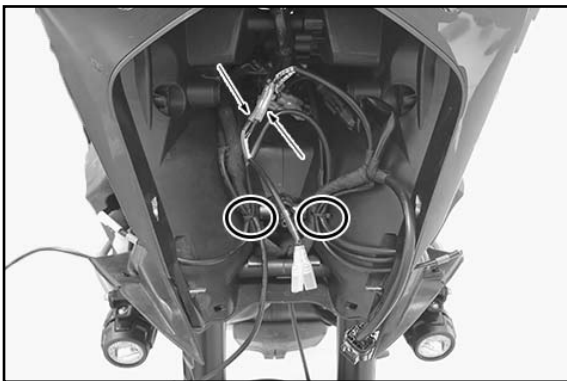

- Kabelstrang 2 mit ACC2 des Fahrzeug-Kabelstrangs verbinden.

HINWEIS

Auf den Kabeln befindet sich ein Aufkleber mit der Aufschrift ACC 2.

- Kabel spannungsfrei verlegen und mit Kabelbindern (Lieferumfang) sichern.

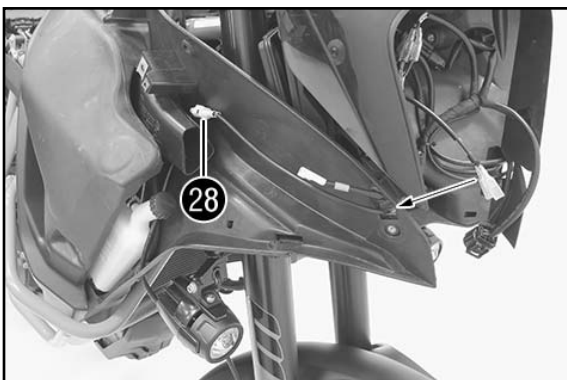

- Kabel für rechten Nebelscheinwerfer wie dargestellt verlegen.
- Steckerverbindung 28 zusammenstecken.

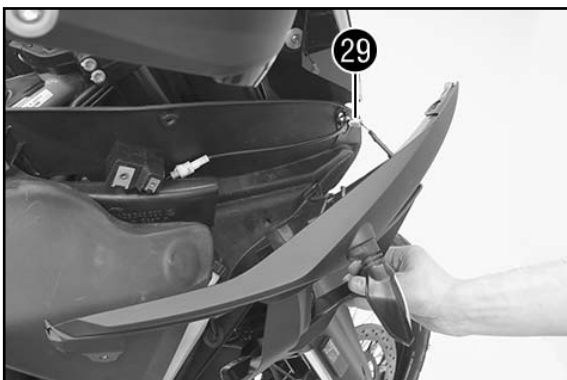

Maskenspoiler einbauen

- Rechten Maskenspoiler positionieren.
- Steckerverbindung 29 zusammenstecken.



- Haltenase in der Bohrung positionieren und Maskenspoiler in die Aufnahmen drücken.

HINWEIS

Auf die korrekte Verlegung des Blinkerkabels achten.
Auf den richtigen Sitz des Ansaugschnorchels achten.

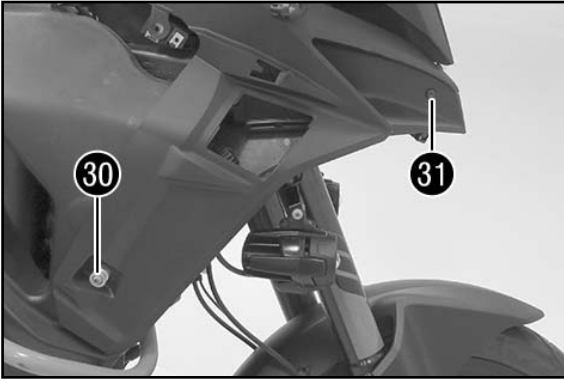

- Schraube 30 mit Buchse montieren und mit 4 Nm festziehen.
- Schraube 31 montieren und mit 3,5 Nm festziehen.

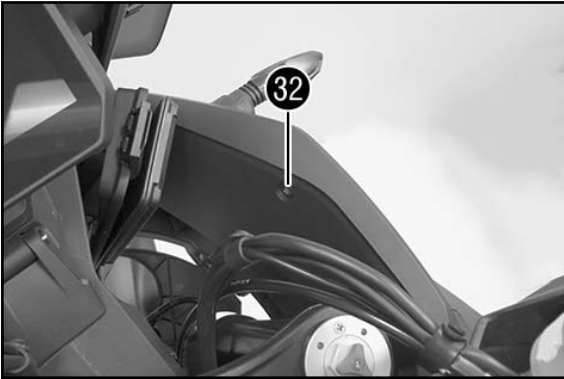

- Schraube 32 montieren und mit 3,5 Nm festziehen.
- Arbeitsschritte auf der linken Seite wiederholen.

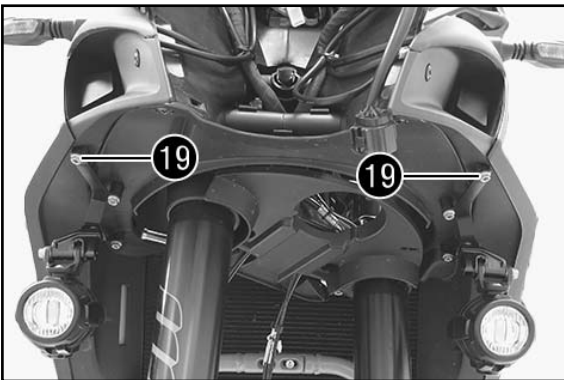

- Schrauben 19 montieren und mit 3,5 Nm festziehen.

Nacharbeit

- Scheinwerfer einbauen (s. Reparaturanleitung). 🔧
- Tankabdeckung einbauen (s. Bedienungsanleitung).
- Seitenverkleidung vorne einbauen (s. Bedienungsanleitung).
- Sitzbank montieren (s. Bedienungsanleitung).

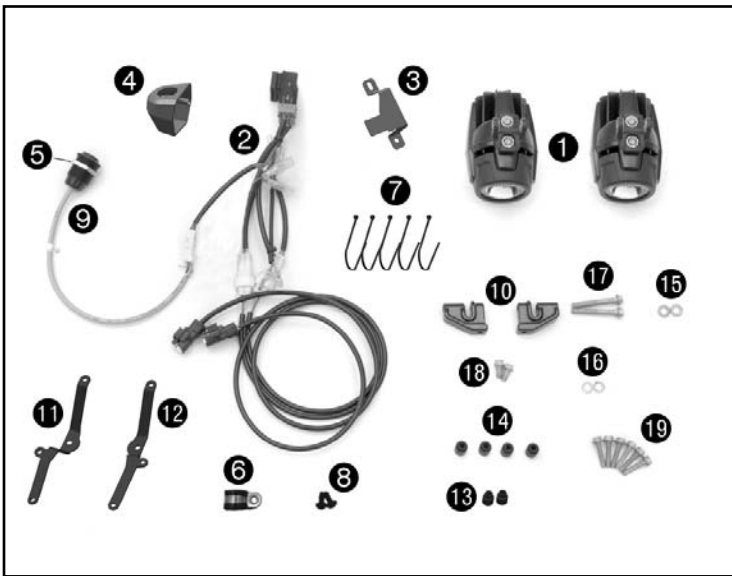

Scope of supply

- 2x fog light ①
- 1x wiring harness ②
- 1x retaining bracket, relay ③
- 1x switch housing ④
- 1x nut for switch ⑤
- 1x clamp ⑥
- 5x cable tie ⑦
- 2x screw ⑧
- 1x switch ⑨
- 1x mounting kit, supplementary headlight
 - 2x hinge piece ⑩
 - 1x retaining bracket, left headlight ⑪
 - 1x retaining bracket, right headlight ⑫
 - 2x short bushing ⑬
 - 4x long bushing ⑭
 - 2x washer ⑮
 - 2x Nord-lock washer ⑯
 - 2x collar screw M6x45 ⑰
 - 2x collar screw M6x12 ⑱
 - 6x collar screw M6x25 ⑲

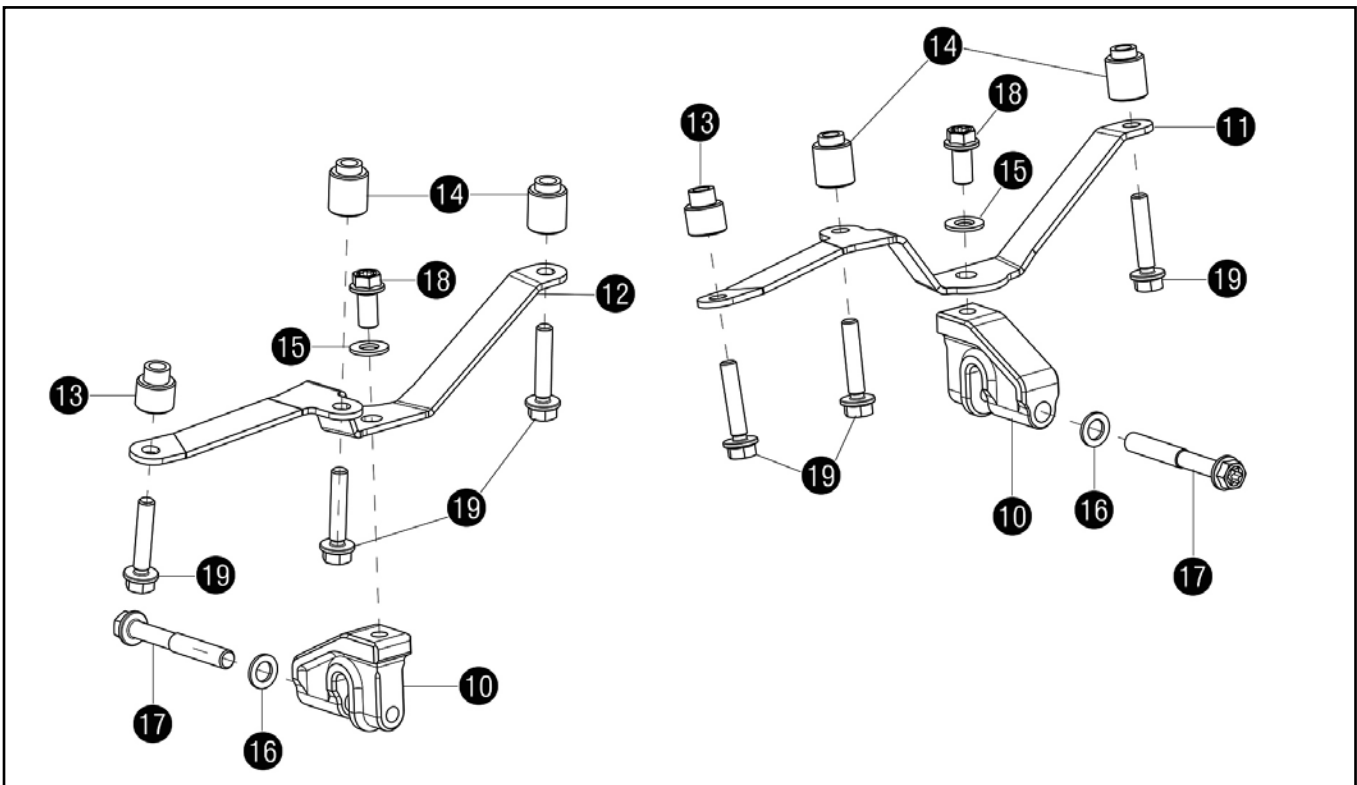

All work marked with this symbol requires specialist knowledge and technical understanding. In the interests of your own safety, have these jobs performed by an authorized KTM workshop. There, your motorcycle will be optimally cared for by specially trained experts using the auxiliary tools required.

Preparatory work

- Take off the seat (see user Manual).
- Remove front side cover (see user manual).
- Remove mask spoiler (see user manual).
- Remove tank cover (see user manual).
- Remove headlight (see repair manual).

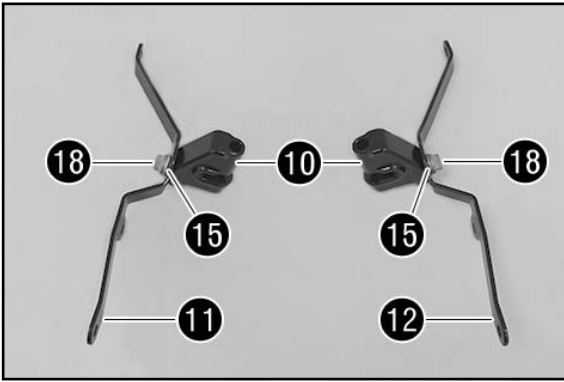

Preassembly

- Position retaining brackets, left **11** and right, **12** on hinge piece **10** (all included).
- Mount screws **18** with washers **15** and tighten.

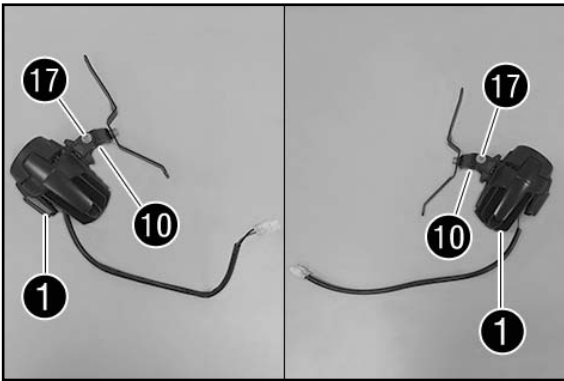

- Position fog light **1** (included) on the hinge piece **10**.
- Mount screws **17** with Nord-lock washers **16** (all included) and tighten.

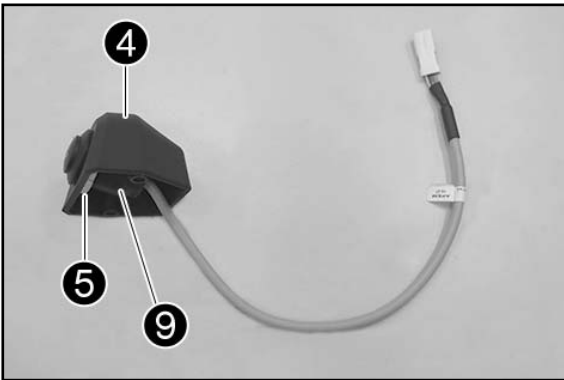

- Mount switch **9** in switch housing **4** (all included).
- Mount nut **5** for the switch (included) and tighten.

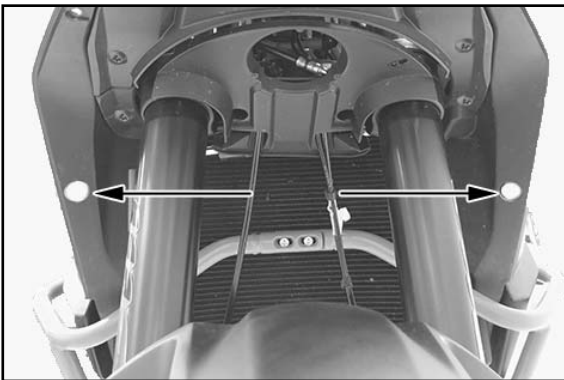

Assembly

- Drill a mounting hole (Ø 22 mm) on both sides of the inside cover, as shown, using appropriate tools.

! ATTENTION
When drilling, make sure that none of the components are damaged!

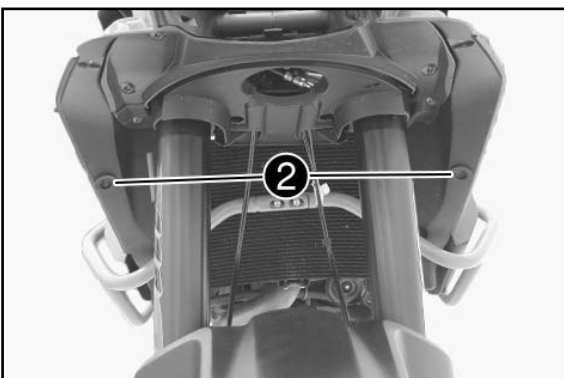

- Position cable grommets **2** (included with wiring harness) in the holes.

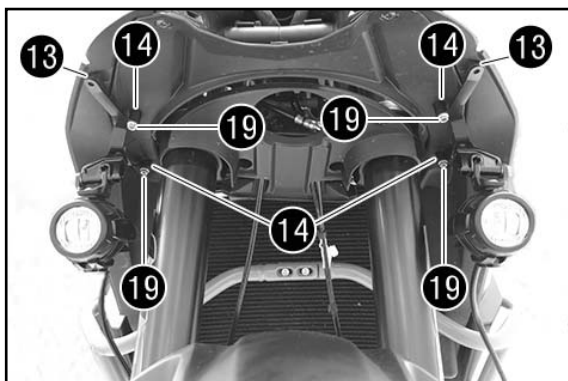

- Position retaining bracket with fog lights, left 11 and right 12.
- Mount short bushings 13 (included).
- Mount screws 19 with long bushings 14 (all included) and tighten to 3.5 Nm.

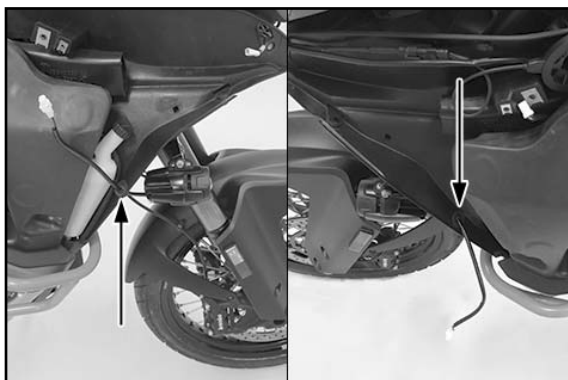

- Route fog light cables on both sides through the cable grommets.

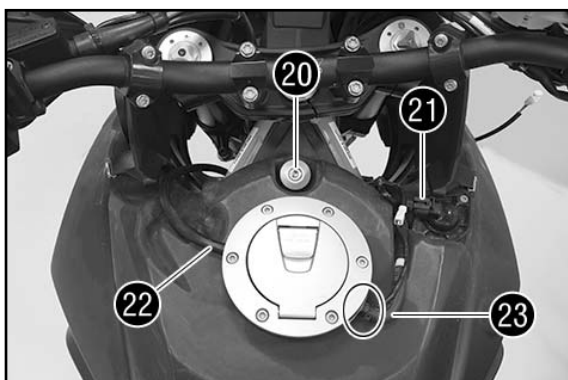

Route the wiring harness

- Remove screws 20 with bearing sleeve and rubber bushing.
- Disconnect connector 21.
- Pull off vent hose 22.
- Remove the cable tie(s).
- Pull off vent hose 23.



- Remove screws 24 with bushings.
- Raise the fuel tank and pull to the rear.

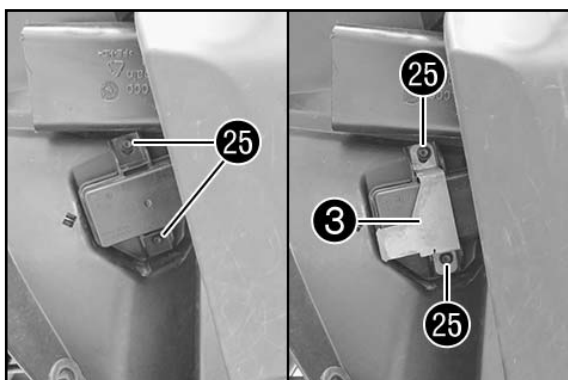

- Remove screws 25.
- Mount retaining bracket 3 (included) with screws 25 and tighten.

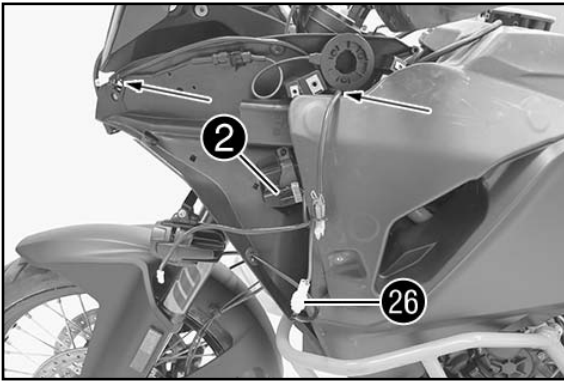

- Route wiring harness (included) without tension toward the headlight as shown.
- Mount relay 2 (included with wiring harness) on the retaining bracket 3.
- Join plug-in connector 26 together.

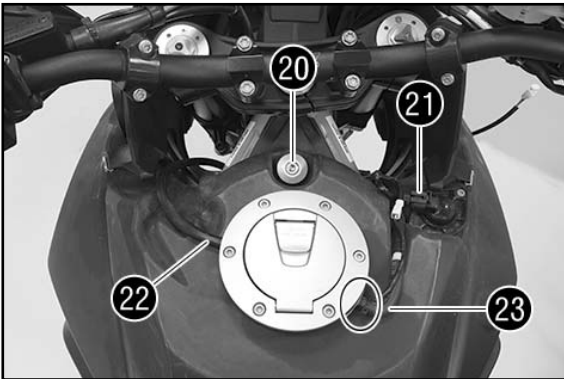

- Position the fuel tank.
- Mount screw 20 with bearing sleeve and rubber bushing and tighten to 15 Nm.
- Plug in connector 21.
- Mount vent hoses 22 and 23.
- Mount cable tie(s).

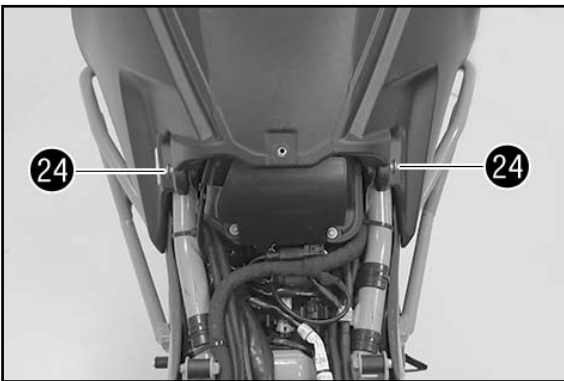

- Mount screws 24 with bushings on both sides and tighten to 10 Nm.

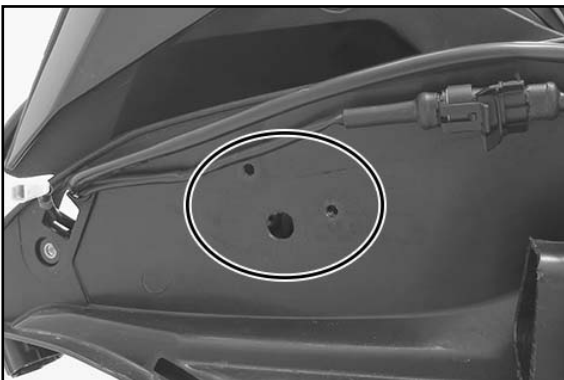

Mount switch

- Drill mounting holes (Ø 22 mm and Ø 5 mm) using appropriate tool.

NOTE

The positions are marked on the trim.

! ATTENTION

When drilling, make sure that none of the components are damaged!

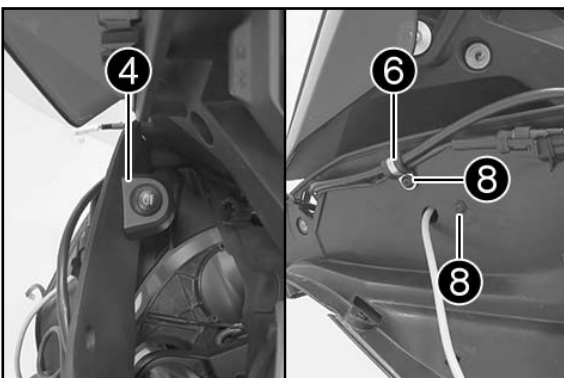

- Position switch housing 4 with switch (included).
- Route through the hole.
- Position clamp 6 (included).
- Mount and tighten screws 8 (included).



- Join plug-in connector 27 together.
- Route the cable without tension.

! ATTENTION

Ensure that the cables are not kinked or pinched!

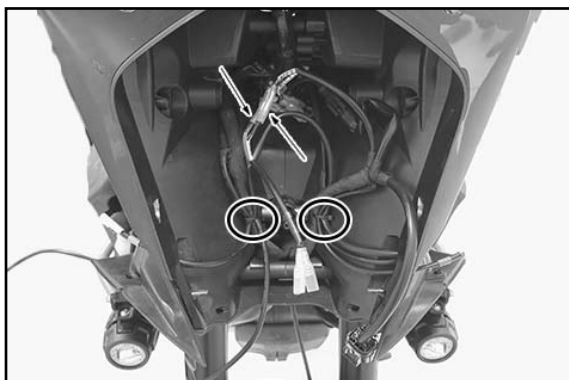

- Connect wiring harness 2 with ACC2 of the vehicle wiring harness.

NOTE

The cables have an adhesive label marked with ACC 2.

- Route the cable without tension and secure with cable ties (included).

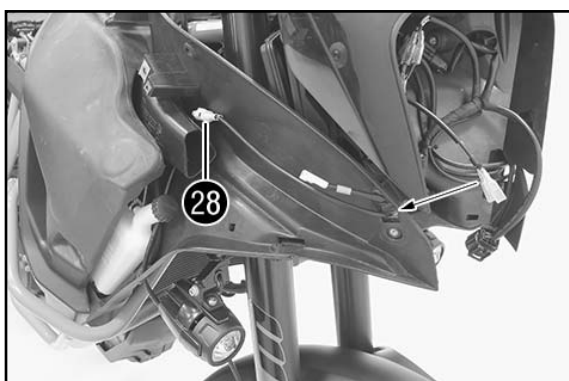

- Route cable for right fog light as shown.
- Join plug-in connector 28.

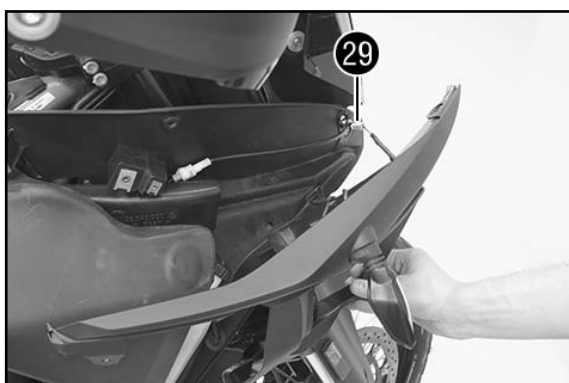

Installing the mask spoiler

- Position right mask spoiler.
- Join plug-in connector 29.

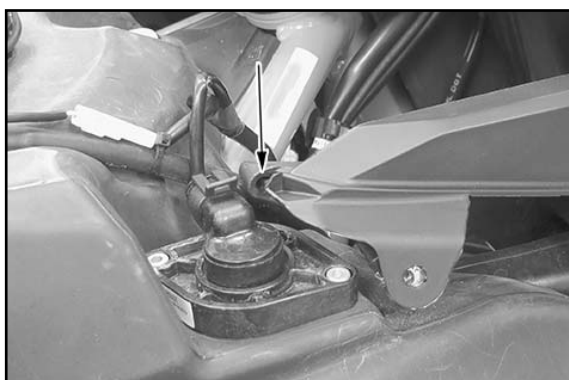

- Position holding lug in the hole and press the mask spoiler in the mountings.

NOTE

Ensure that the turn signal cable is routed correctly.
Ensure that the intake snorkel is seated properly.

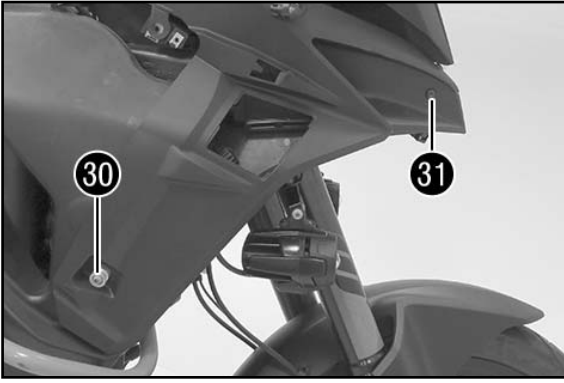

- Mount screw 30 with bushing and tighten to 4 Nm.
- Mount screw 31 and tighten to 3.5 Nm.



- Mount screw 32 and tighten to 3.5 Nm.
- Repeat these steps on the left side.

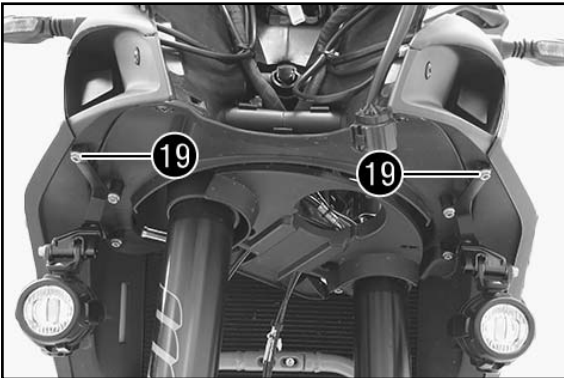

- Mount screws 19 and tighten to 3.5 Nm.

Final steps

- Install headlight (see repair manual). 
- Install tank cover (see user manual).
- Install front side cover (see user manual).
- Mount the seat (see user manual).

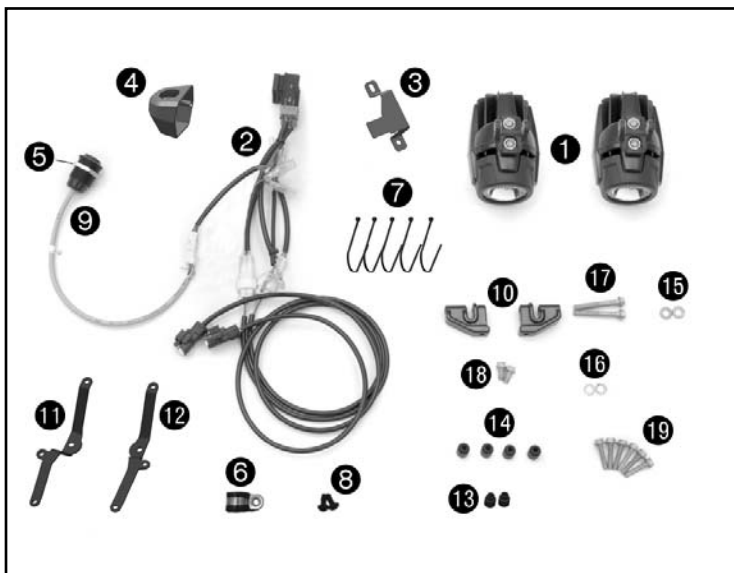

Materiale fornito

- 2 fendinebbia ①
- 1 cablaggio ②
- 1 piastrina per il relè ③
- 1 custodia dell'interruttore ④
- 1 dado per l'interruttore ⑤
- 1 fascetta ⑥
- 5 fascette serracavi ⑦
- 2 viti ⑧
- 1 interruttore ⑨
- 1 kit di montaggio faro supplementare
 - 2 pezzi articolati ⑩
 - 1 piastrina per il faro di sinistra ⑪
 - 1 piastrina per il faro di destra ⑫
 - 2 boccole corte ⑬
 - 4 boccole lunghe ⑭
 - 2 rondelle ⑮
 - 2 rondelle Nord-Lock ⑯
 - 2 viti flangiate M6x45 ⑰
 - 2 viti flangiate M6x12 ⑱
 - 6 viti flangiate M6x25 ⑲

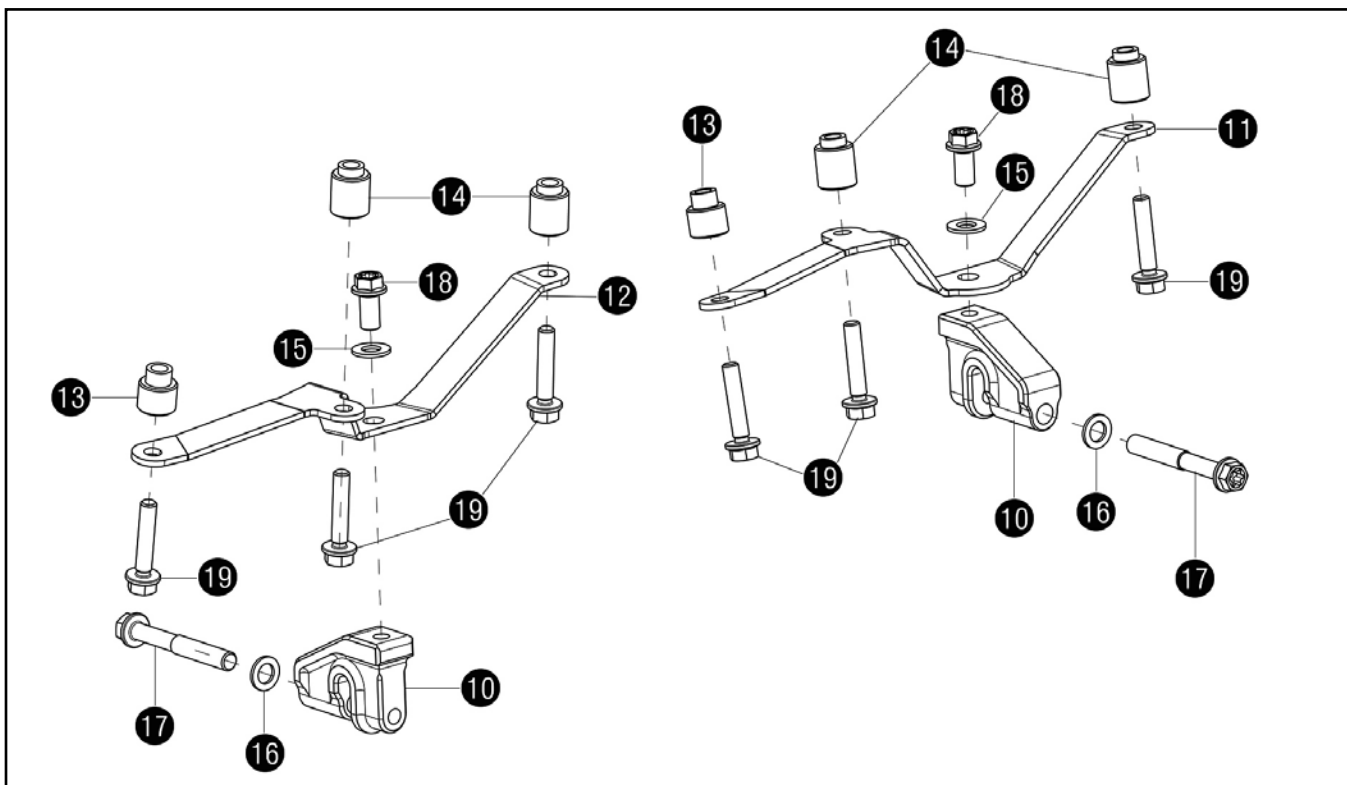

 Tutti i lavori contrassegnati con questo simbolo richiedono competenze tecniche e comprensione della materia. Per la vostra sicurezza, far eseguire questi interventi presso un'officina autorizzata KTM che si occuperà della vostra motocicletta in modo ottimale, impiegando manodopera specializzata e addestrata, e utilizzando i necessari utensili speciali.

Operazione preliminare

- Rimuovere la sella (v. manuale d'uso).
- Smontare la fiancatina anteriore (v. manuale d'uso).
- Smontare la mascherina dello spoiler (v. manuale d'uso).
- Smontare il copriserbatoio (v. manuale d'uso).
- Smontare il faro (v. manuale di riparazione). 

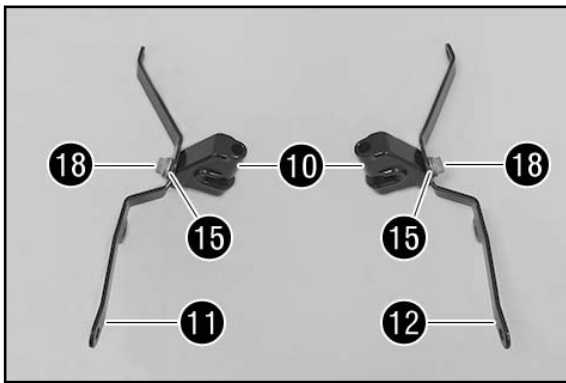

Premontaggio

- Posizionare le piastrelle sinistra 11 e destra 12 sui pezzi articolati 10 (tutto in dotazione).
- Montare le viti 18 con le rondelle 15 e serrare.

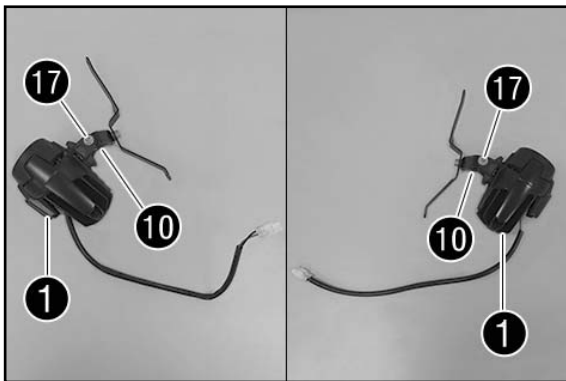

- Posizionare il fendinebbia 1 (in dotazione) sui pezzi articolati 10.
- Montare le viti 17 con le rondelle Nord-Lock 16 (tutto in dotazione) e serrare.

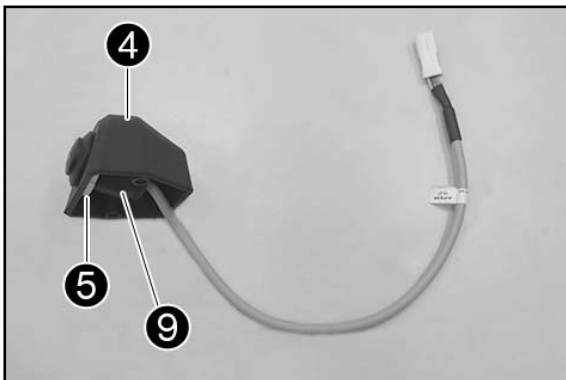

- Montare l'interruttore 9 nella sua custodia 4 (tutto in dotazione).
- Montare e serrare il dado 5 dell'interruttore (in dotazione).

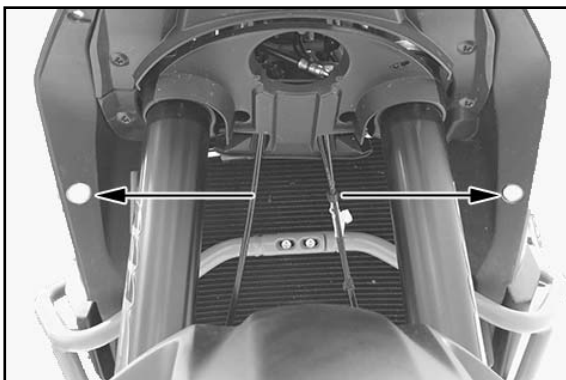

Montaggio

- Con un attrezzo idoneo, su entrambi i lati del rivestimento interno realizzare il foro di montaggio come illustrato (Ø 22 mm).

! AVVERTIMENTO

Nel realizzare il foro prestare attenzione a non danneggiare nessun componente!

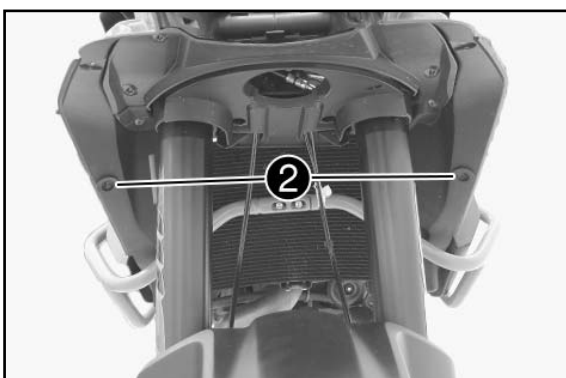

- Posizionare i passacavi 2 (dotazione cablaggio) nei fori.

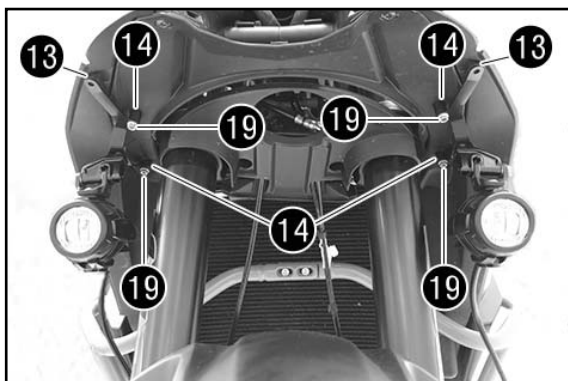

- Posizionare la piastrina con il fendinebbia di sinistra 11 e destra 12.
- Montare le boccole corte 13 (in dotazione).
- Montare le viti 19 con le boccole lunghe 14 (tutto in dotazione) e serrare a 3,5 Nm.

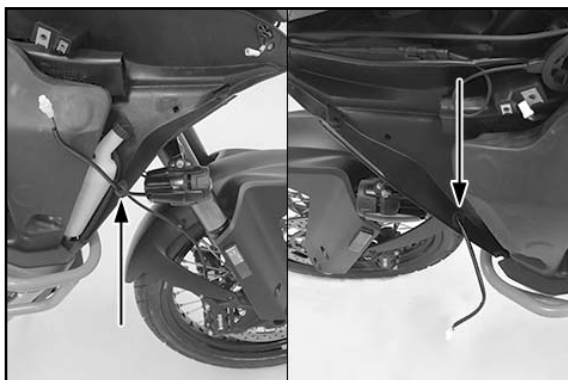

- Disporre il cavo dei fendinebbia su entrambi i lati facendolo passare attraverso i passacavi.

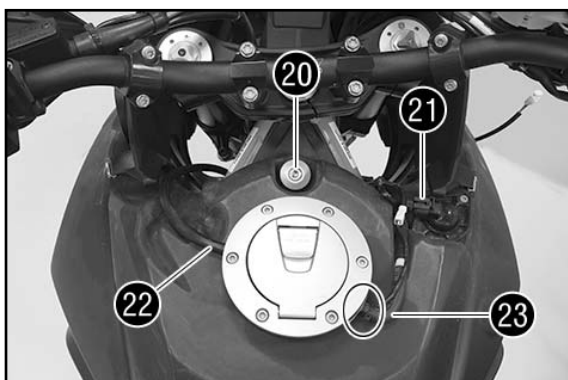

Posare il cablaggio

- Rimuovere la vite 20 con la bussola di supporto e le bussole in gomma.
- Staccare il connettore 21.
- Staccare il tubo di sfiato 22.
- Rimuovere le fascette serracavi.
- Staccare il tubo di sfiato 23.



- Rimuovere le viti 24 con le boccole.
- Sollevare leggermente il serbatoio e tirarlo posteriormente.

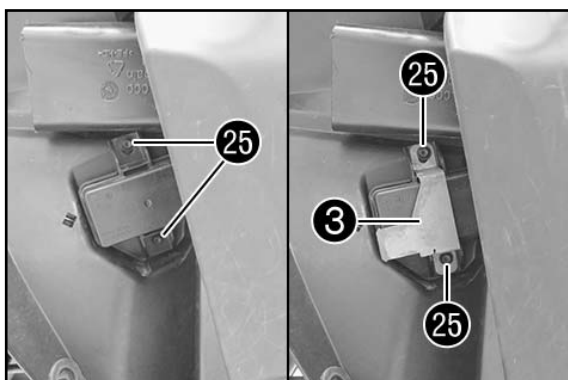

- Rimuovere le viti 25.
- Montare e serrare la piastrina 3 (in dotazione) con le viti 25.

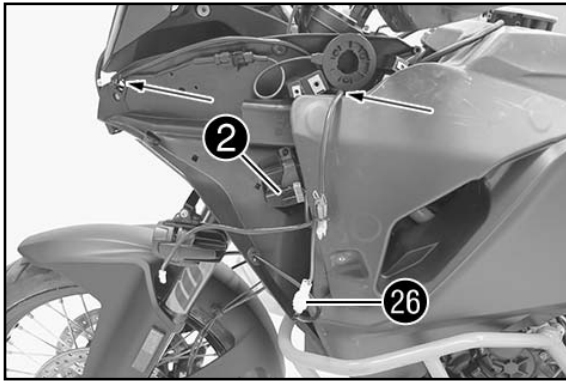

- Posare il cablaggio (in dotazione) in direzione del faro come illustrato, prestando attenzione a non metterlo in tensione.
- Montare il relè ② (dotazione cablaggio) sulla piastrina ③.
- Collegare il connettore ②⑥.

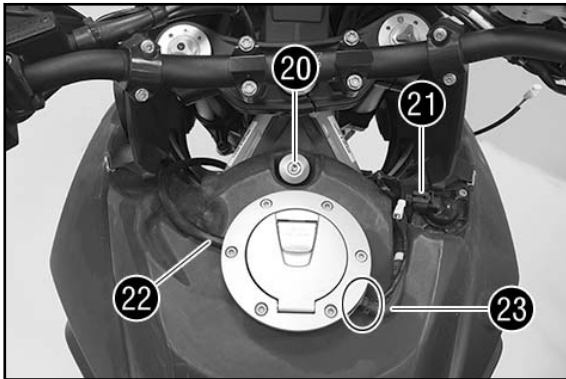

- Posizionare il serbatoio del carburante.
- Montare la vite ②⑩ con la bussola di supporto e le bussole in gomma e serrare a 15 Nm.
- Collegare il connettore ②①.
- Montare i flessibili di sfiato ②② e ②③.
- Montare la fascetta serracavi.

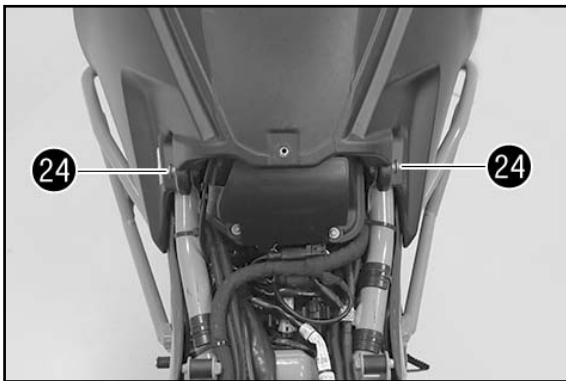

- Montare le viti ②④ con le boccole su entrambi i lati e serrare a 10 Nm.

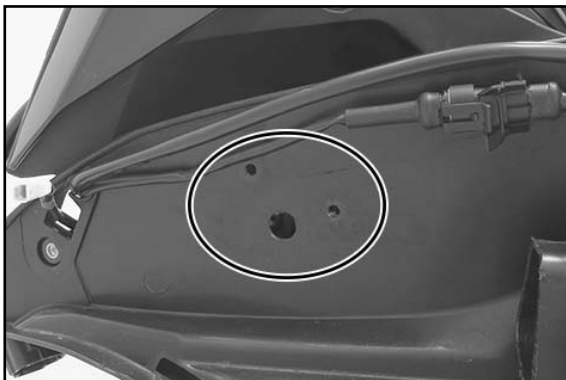

Montaggio dell'interruttore

- Con un attrezzo idoneo realizzare i fori di montaggio (Ø 22 mm e Ø 5 mm).

AVVERTENZA

Le posizioni sono contrassegnate sulla carena.

! AVVERTIMENTO

Nel realizzare il foro prestare attenzione a non danneggiare nessun componente!

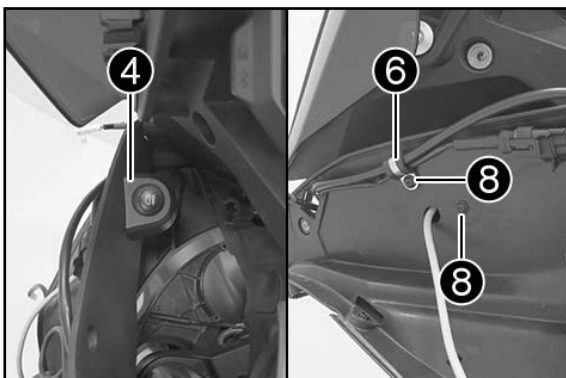

- Posizionare la custodia dell'interruttore ④ con l'interruttore (in dotazione).
- Posare il cavo facendolo passare nel foro.
- Posizionare la fascetta ⑥ (in dotazione).
- Montare e serrare le viti ⑧ (in dotazione).



- Collegare il connettore 27.
- Posizionare il cavo in modo da non metterlo in tensione.

! AVVERTIMENTO

Assicurarsi che i cavi non rischino di venire piegati o bloccati in qualche modo!

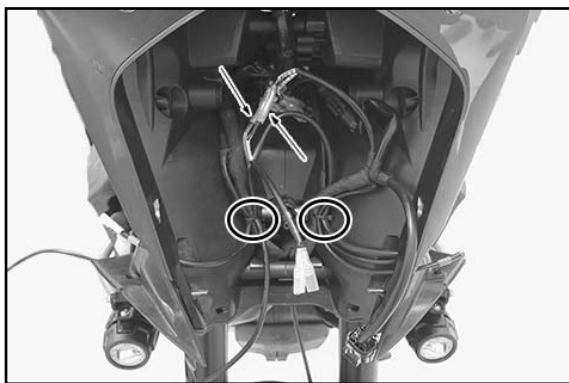

- Collegare il cablaggio 2 all'attacco **ACC2** del cablaggio del veicolo.

AVVERTENZA

Sui cavi è presente un adesivo con la scritta **ACC 2**.

- Posizionare il cavo in modo che non presenti punti in tensione e assicurarlo con le fascette serracavi (in dotazione).

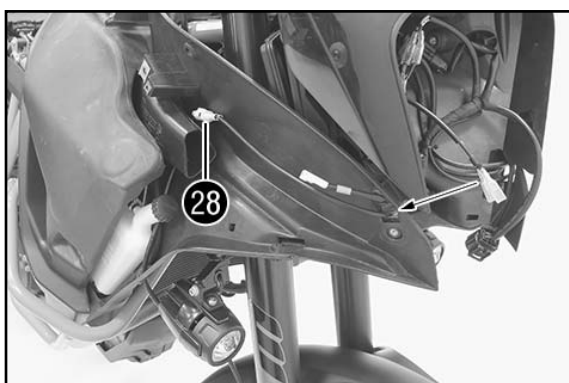

- Posare il cavo per il fendinebbia destro come illustrato.
- Collegare il connettore 28.

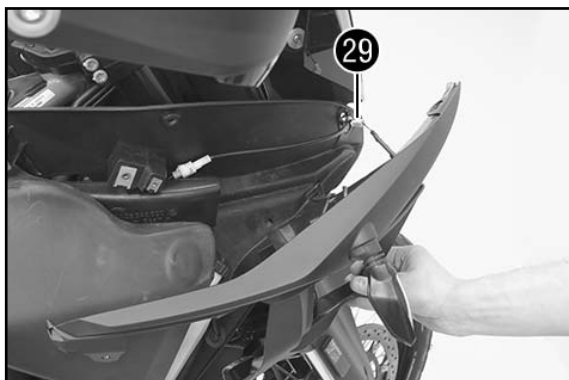

Montaggio dello spoiler sulla mascherina

- Posizionare la mascherina destra dello spoiler.
- Collegare il connettore 29.

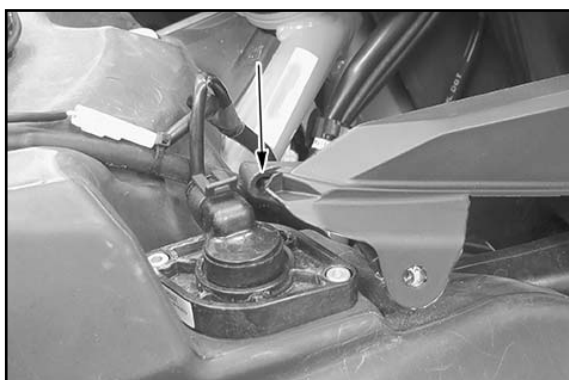

- Posizionare il nasello d'ancoraggio nel foro e spingere la mascherina dello spoiler nella sua sede.

AVVERTENZA

Prestare attenzione alla corretta posa del cavo dell'indicatore di direzione.

Controllare che il tubo di aspirazione sia ben in sede.

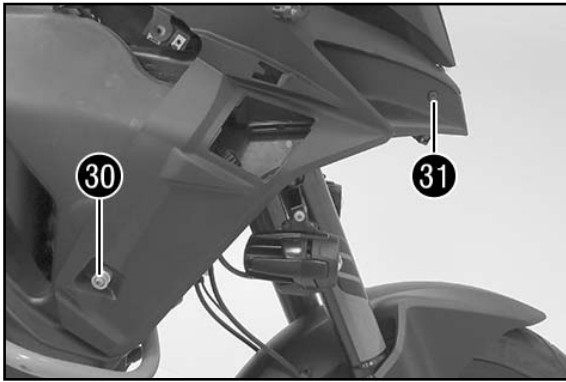

- Montare la vite 30 con la boccola e serrare a 4 Nm.
- Montare la vite 31 e serrare a 3,5 Nm.

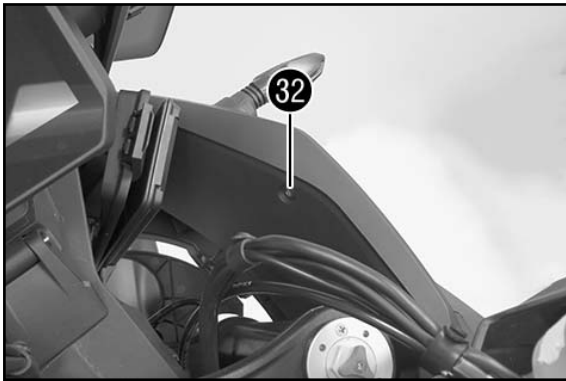

- Montare la vite 32 e serrare a 3,5 Nm.
- Ripetere queste fasi di lavoro sul lato sinistro.

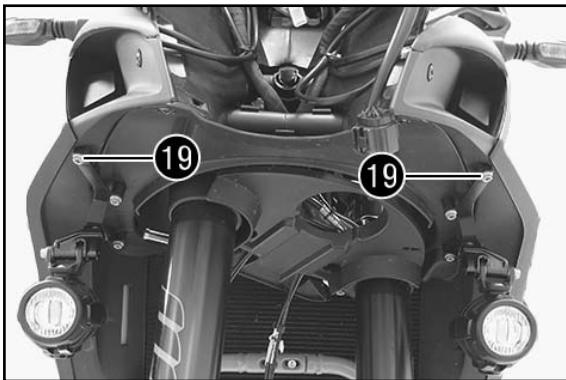

- Montare le viti 19 e serrarle a 3,5 Nm.

Operazione conclusiva

- Montare il faro (v. manuale di riparazione). 
- Montare il copriserbatoio (v. manuale d'uso).
- Montare la fiancatina anteriore (v. manuale d'uso).
- Montare la sella (v. manuale d'uso).

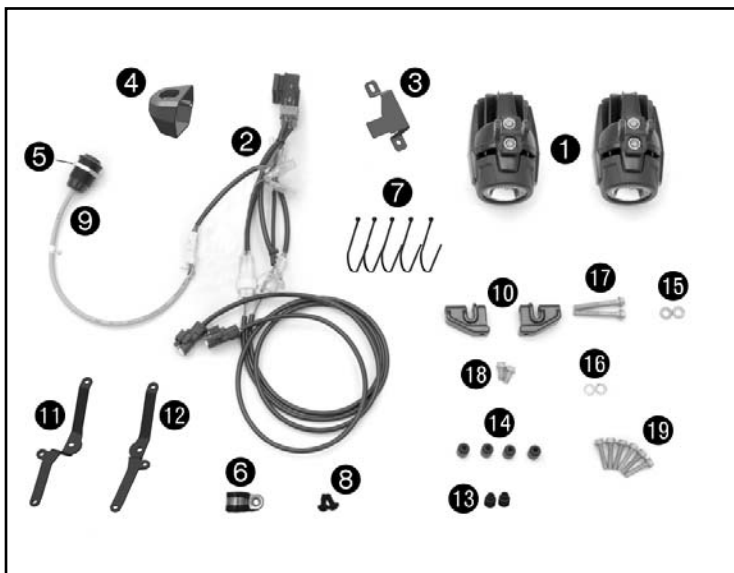

Contenu de la livraison

- 2x phare antibrouillard ①
- 1x faisceau de câbles ②
- 1x tôle de fixation pour relais ③
- 1x boîtier pour bouton ④
- 1x écrou pour bouton ⑤
- 1x collier ⑥
- 5x rilsans ⑦
- 2x vis ⑧
- 1x bouton ⑨
- 1x kit de montage pour phare supplémentaire
 - 2x articulations ⑩
 - 1x tôle de fixation pour phare (gauche) ⑪
 - 1x tôle de fixation pour phare (droite) ⑫
 - 2x bagues courtes ⑬
 - 4x bagues longues ⑭
 - 2x rondelles de calage ⑮
 - 2x rondelles Nordlock ⑯
 - 2x vis à épaulement M6x45 ⑰
 - 2x vis à épaulement M6x12 ⑱
 - 6x vis à épaulement M6x25 ⑲

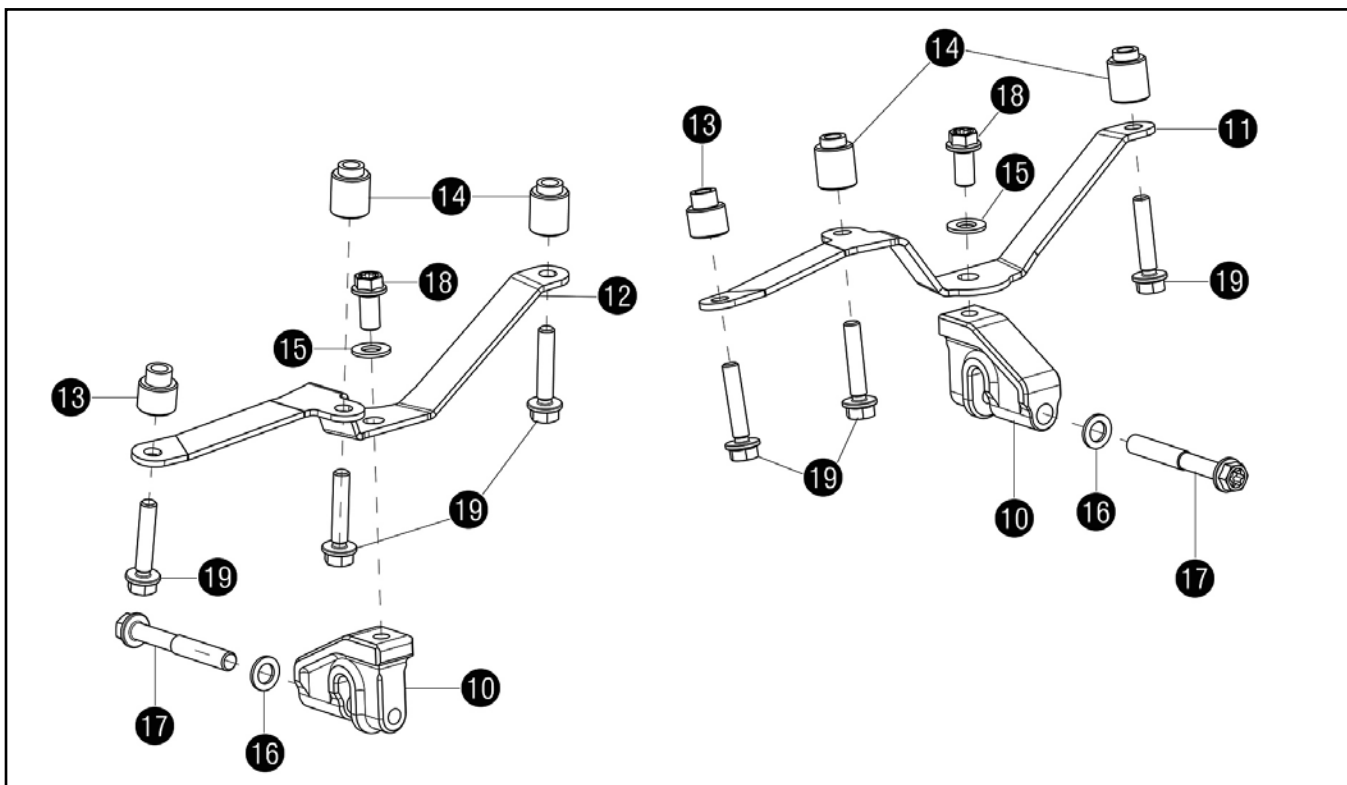

Tous les travaux accompagnés de ce symbole nécessitent des connaissances approfondies ainsi qu'un certain savoir-faire technique.

Pour votre sécurité, faire exécuter ces travaux par un atelier KTM agréé !

La moto y sera entretenue de manière optimale par des spécialistes ayant suivi une formation spécifique et disposant de l'outillage spécial nécessaire.

Travaux préalables

- Déposer la selle (voir manuel d'utilisation).
- Déposer l'habillage latéral avant (voir manuel d'utilisation).
- Déposer le déflecteur de plaque-phare (voir manuel d'utilisation).
- Déposer le cache du réservoir (voir manuel d'utilisation).
- Déposer le phare (voir manuel de réparation).

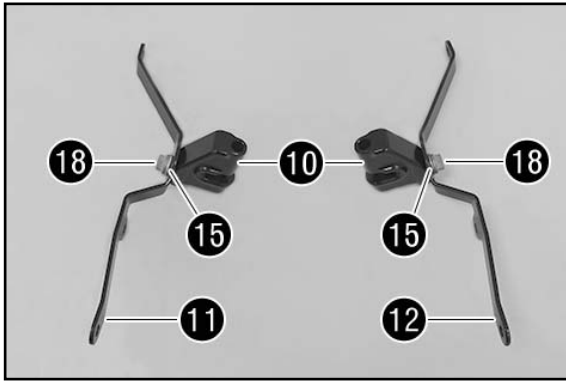

Prémontage

- Positionner les tôles de fixation gauche **11** et droite **12** sur les articulations **10** (toutes fournies).
- Mettre en place les vis **18** avec les rondelles de calage **15** et les serrer.

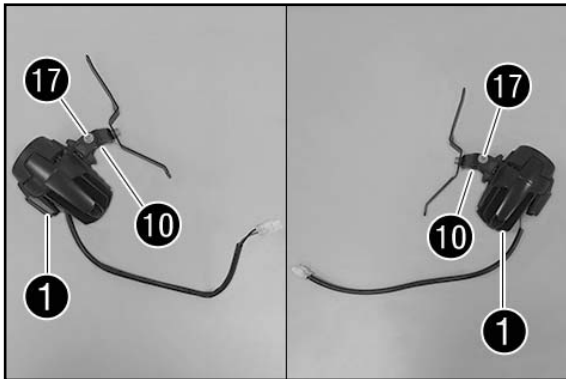

- Mettre en place le phare antibrouillard **1** (fourni) sur les articulations **10**.
- Mettre en place les vis **17** et les rondelles Nordlock **16** (toutes fournies) et les serrer.

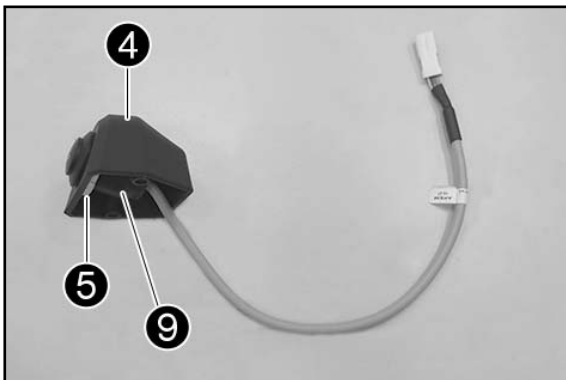

- Mettre en place le bouton **9** dans le boîtier pour bouton **4** (tous fournis).
- Mettre en place l'écrou **5** du bouton (fourni) et le serrer.

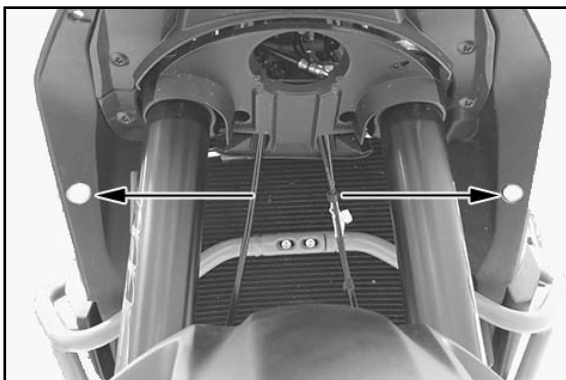

Montage

- Utiliser un outil adapté pour percer un trou de montage (\varnothing 22 mm) des deux côtés du garnissage intérieur, comme illustré.

! ATTENTION

Lors du perçage, veiller à ne pas endommager les composants !

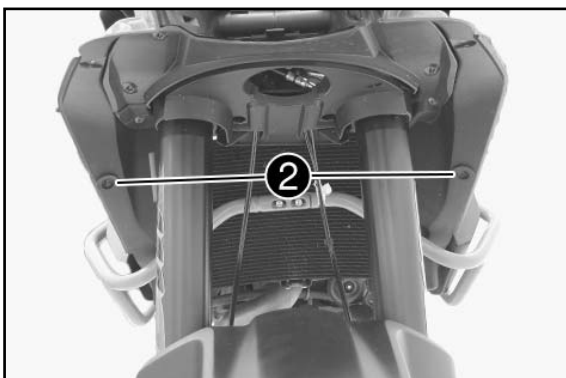

- Placer les cache-câbles **2** (fournis avec le faisceau de câbles) dans les alésages.

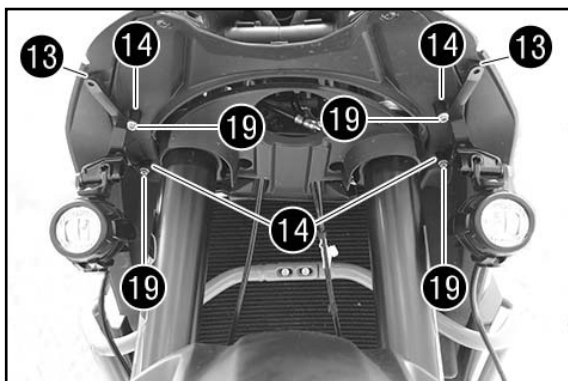

- Positionner les tôles de fixation et phares antibrouillard de gauche ⑪ et de droite ⑫.
- Mettre en place les bagues courtes ⑬ (fournies).
- Mettre en place les vis ⑱ avec les bagues longues ⑭ (toutes fournies) et les serrer à 3,5 Nm.

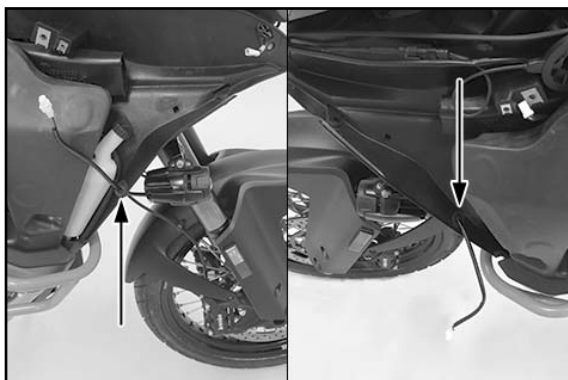

- Faire passer le câble du phare additionnel des deux côtés à travers les cache-câbles.

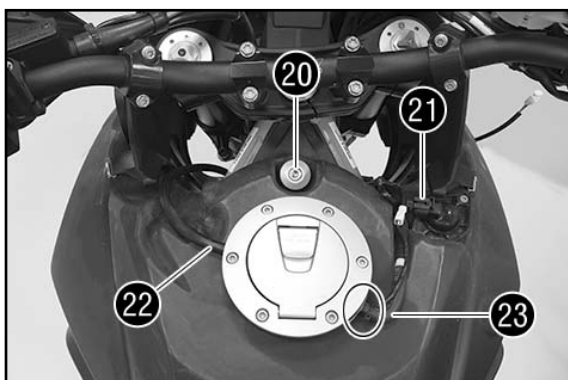

Pose du faisceau de câbles

- Retirer la vis ⑳ avec le coussinet et la bague en caoutchouc.
- Débrancher le connecteur ㉑.
- Débrancher le reniflard ㉒.
- Retirer le rilsan.
- Débrancher le reniflard ㉓.



- Enlever les vis ㉔ et les bagues.
- Soulever légèrement le réservoir et l'enlever par l'arrière.

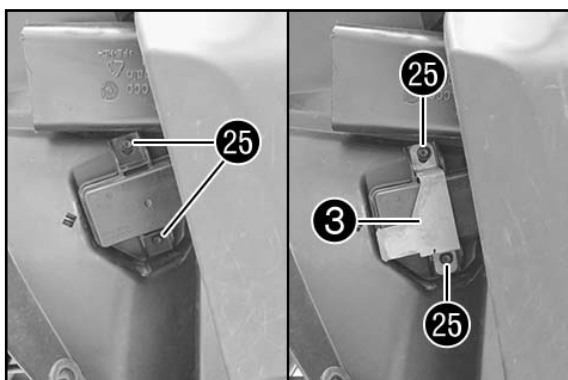

- Retirer les vis ㉕.
- Mettre en place la tôle de fixation ③ (fournie) avec les vis ㉖ et les serrer.

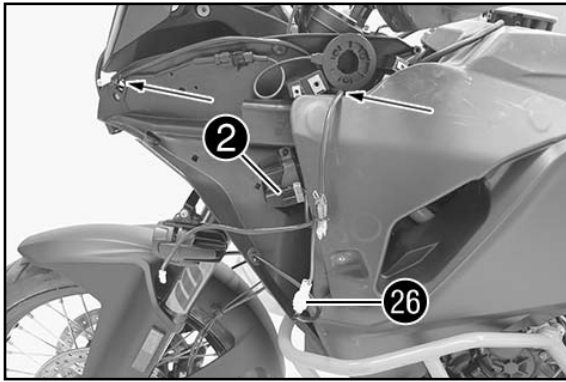

- Poser le faisceau de câbles (fourni) comme illustré, en direction du phare et de manière à ce qu'il ne soit soumis à aucune contrainte.
- Mettre en place le relais ② (fourni avec le faisceau de câbles) sur la tôle de fixation ③.
- Brancher le connecteur ②⑥.

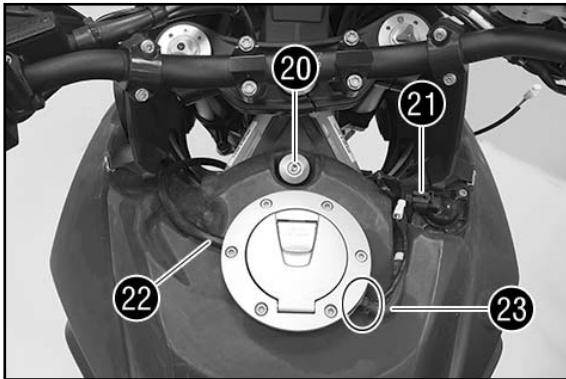

- Mettre en place le réservoir de carburant.
- Mettre la vis ②⑩ en place avec le coussinet et la bague en caoutchouc et serrer à 15 Nm.
- Brancher le connecteur ②①.
- Mettre en place les flexibles de purge ②② et ②③.
- Monter le rilsan.



- Mettre en place les vis ②④ avec les bagues des deux côtés et les serrer à 10 Nm.

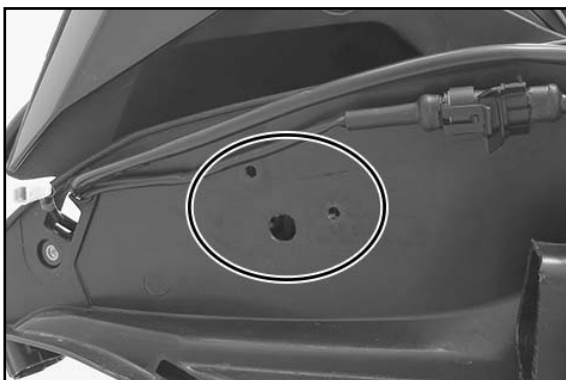

Mise en place du bouton

- Utiliser un outil adapté pour percer des trous de montage (Ø 22 mm et Ø 5 mm).

REMARQUE

Les emplacements sont indiqués sur le carénage.

! ATTENTION
Lors du perçage, veiller à ne pas endommager les composants !

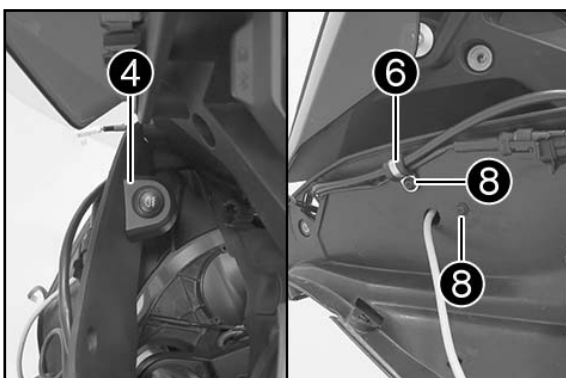

- Mettre en place le boîtier pour bouton ④ avec le bouton (fournis).
- Faire passer le câble à travers l'alésage.
- Mettre en place le collier ⑥ (fourni).
- Mettre les vis ⑧ (fournies) en place et les serrer.



- Brancher le connecteur 27.
- Poser le câble de manière à ce qu'il ne soit soumis à aucune contrainte.

! ATTENTION

S'assurer que le câble ne peut ni être plié, ni rester coincé !

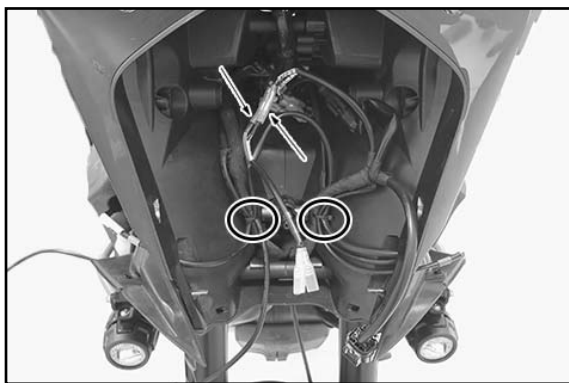

- Connecter le faisceau de câbles 2 avec ACC2 du faisceau de câbles du véhicule.

REMARQUE

Les câbles sont dotés d'une étiquette portant l'inscription ACC2.

- Poser le câble de manière à ce qu'il ne soit soumis à aucune contrainte et le fixer à l'aide de rilsans (fournis).

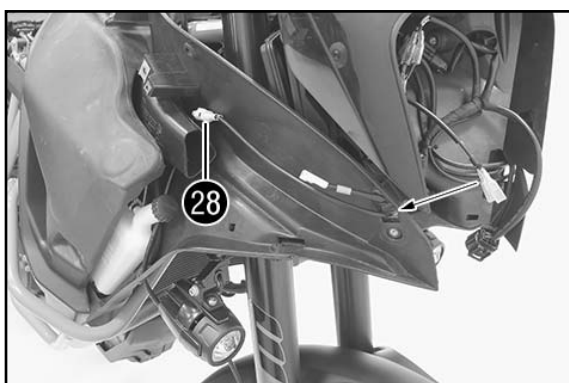

- Poser le câble du phare antibrouillard droit comme illustré.
- Brancher le connecteur 28.

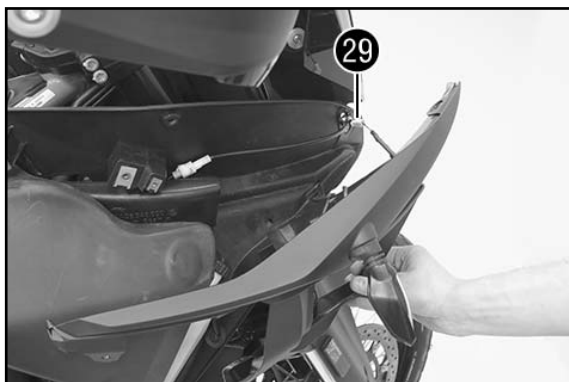

Monter le déflecteur de plaque-phare

- Mettre en place le déflecteur de plaque-phare droit.
- Brancher le connecteur 29.

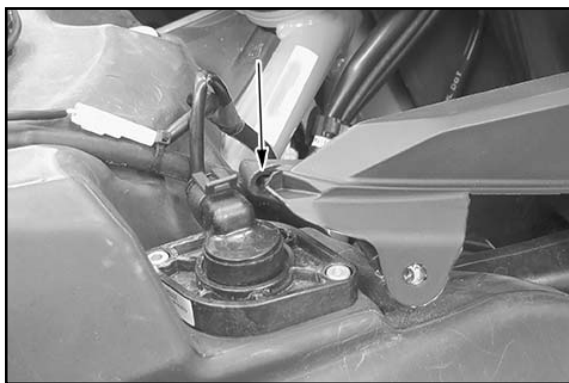

- Mettre en place le crochet dans l'alésage et presser le déflecteur de plaque-phare dans les fixations.

REMARQUE

Prendre garde au passage du câble de clignotant. Veiller à ce que la durite d'aspiration soit bien en place.

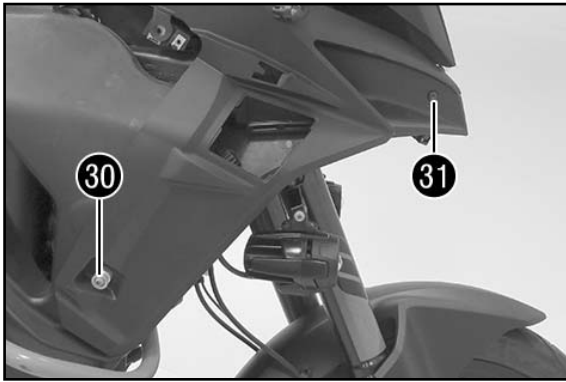

- Mettre en place la vis 30 avec la bague et la serrer à 4 Nm.
- Mettre en place les vis 31 et les serrer à 3,5 Nm.

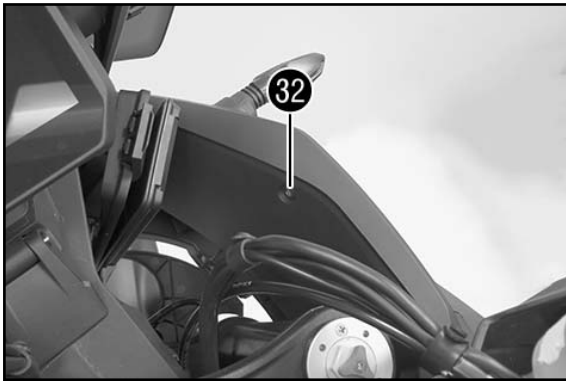

- Mettre en place la vis 32 et la serrer à 3,5 Nm.
- Répéter les étapes de travail du côté gauche.

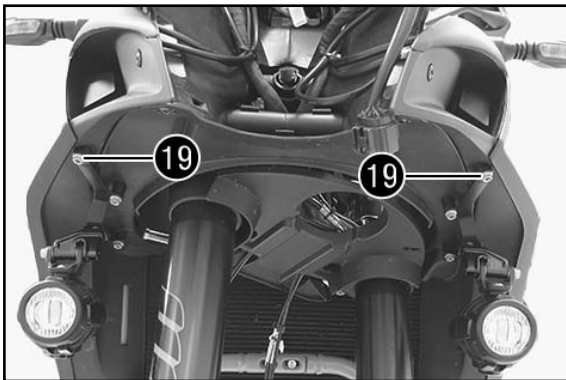

- Mettre en place les vis 19 et les serrer à 3,5 Nm.

Travaux ultérieurs

- Monter le phare (voir manuel de réparation). 
- Monter le cache du réservoir (voir manuel d'utilisation).
- Monter l'habillage latéral avant (voir manuel d'utilisation).
- Poser la selle (voir manuel d'utilisation).

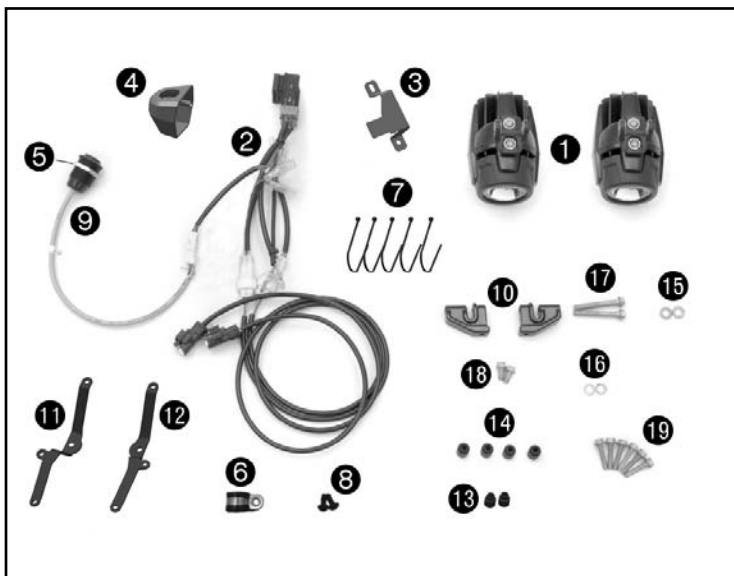

Volumen de suministro

- 2x faro antiniebla ①
- 1x ramal de cables ②
- 1x retenedor del relé ③
- 1x carcasa del interruptor ④
- 1x tuerca para interruptor ⑤
- 1x abrazadera ⑥
- 5x bridas ⑦
- 2x tornillos ⑧
- 1x interruptor ⑨
- 1x kit de montaje para faro suplementario
 - 2x piezas de articulación ⑩
 - 1x retenedor para faro izquierdo ⑪
 - 1x retenedor para faro derecho ⑫
 - 2x casquillos cortos ⑬
 - 4x casquillos largos ⑭
 - 2x arandelas ⑮
 - 2x arandelas Nordlock ⑯
 - 2x tornillos de collarín M6x45 ⑰
 - 2x tornillos de collarín M6x12 ⑱
 - 6x tornillos de collarín M6x25 ⑲

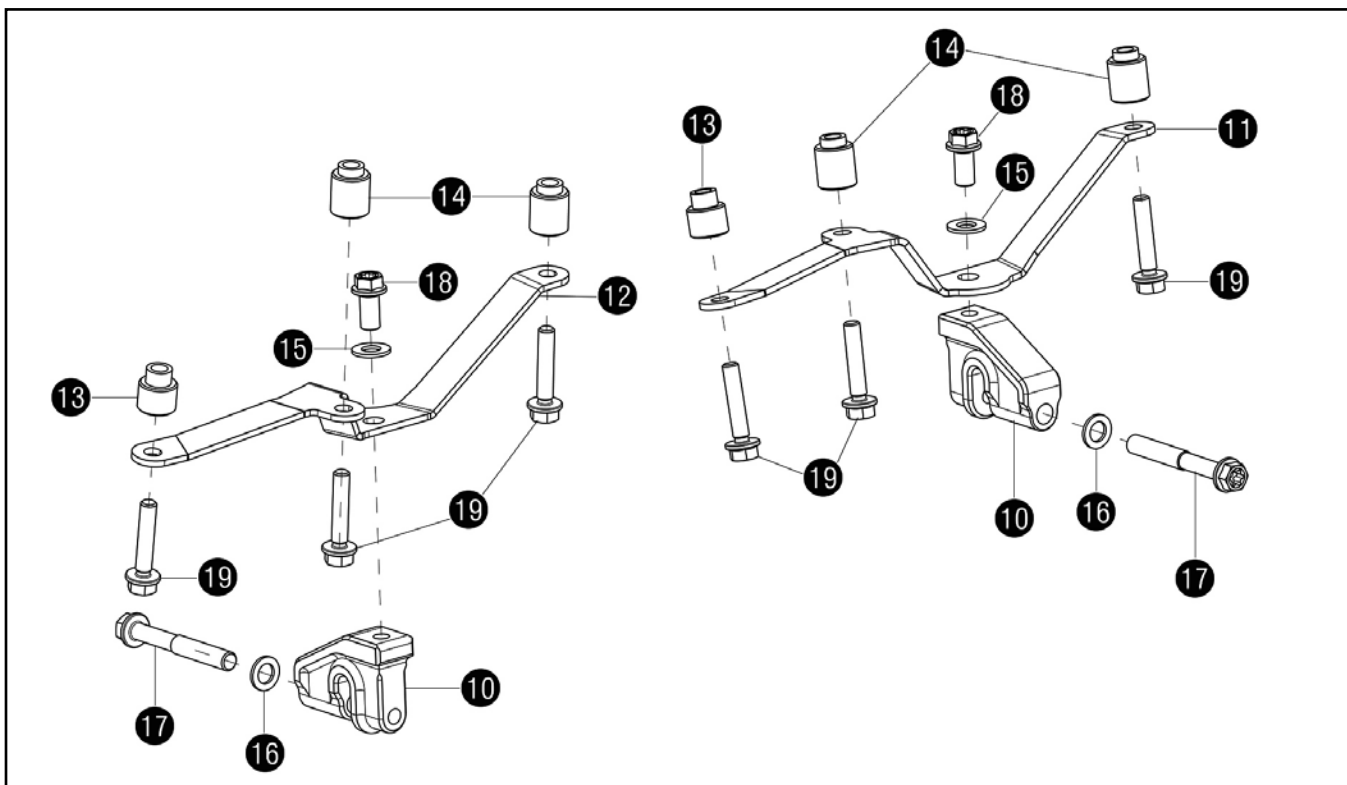

 Todas las tareas marcadas con este símbolo requieren conocimientos especiales y capacidad de comprensión técnica. Por su seguridad, le aconsejamos que acuda a un taller especializado autorizado KTM para llevar a cabo estas tareas. Estos talleres cuentan con mecánicos que han recibido una instrucción específica y disponen de las herramientas especiales necesarias para realizar el mantenimiento ideal de su motocicleta.

Trabajos previos

- Quitar el asiento (véase el manual de instrucciones).
- Desmontar el carenado lateral delantero (véase el manual de instrucciones).
- Desmontar el spoiler del soporte del faro (véase el manual de instrucciones).
- Desmontar el carenado del depósito (véase el manual de instrucciones).
- Desmontar el faro (véase el manual de reparación). 

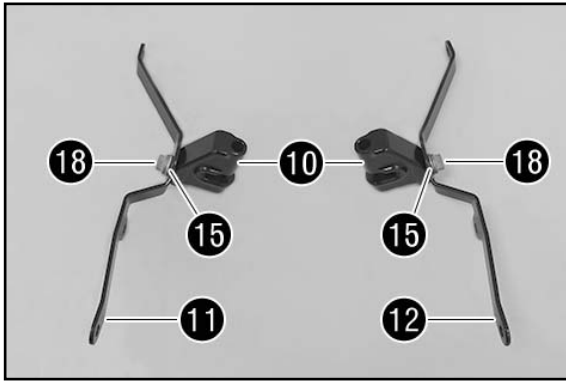

Tareas previas de montaje

- Posicionar los retenedores izquierdo (11) y derecho (12) en las piezas de articulación (10) (todo incluido en el volumen de suministro).
- Montar y apretar los tornillos (18) con las arandelas (15).

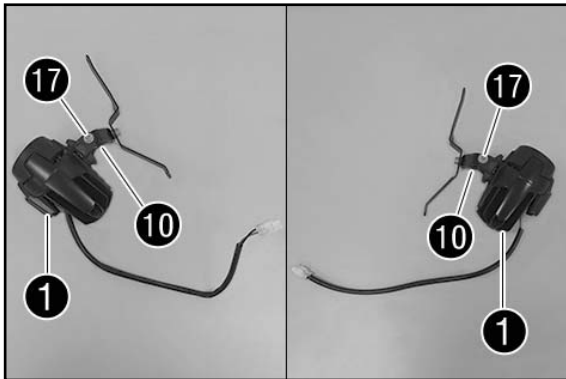

- Colocar el faro supplémentaire (1) (volumen de suministro) sobre la pieza de articulación (10).
- Montar y apretar los tornillos (17) con las arandelas Nordlock (16) (todo ello incluido en el volumen de suministro).

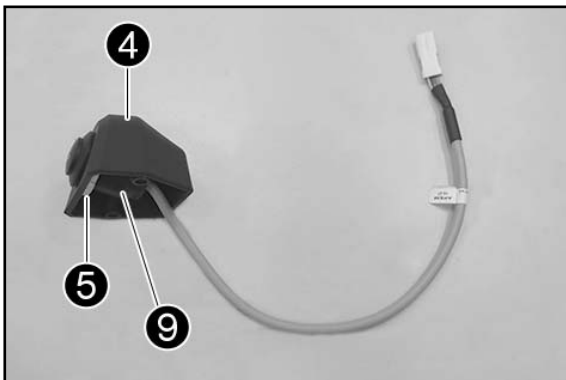

- Montar el interruptor (9) en su carcasa (4) (todo incluido en el volumen de suministro).
- Montar y apretar la tuerca (5) del interruptor (volumen de suministro).

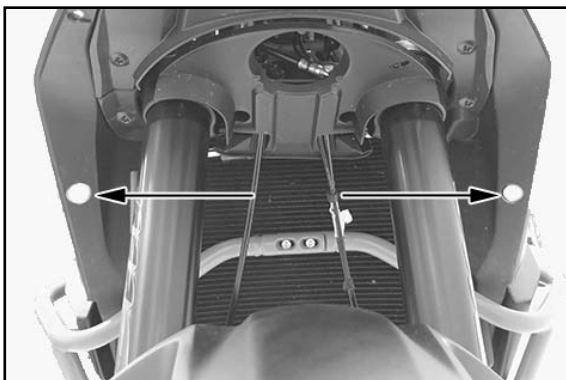

Montaje

- Perforar los orificios de montaje (Ø 22 mm) a ambos lados del carenado interior con la herramienta adecuada tal como se muestra en la figura.

! AVISO

Durante la perforación, tener cuidado de que ningún componente sufra daños.

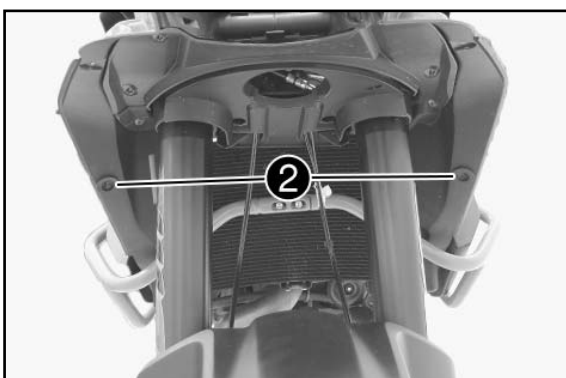

- Posicionar los manguitos para cables (2) (volumen de suministro del ramal de cables) en los orificios.

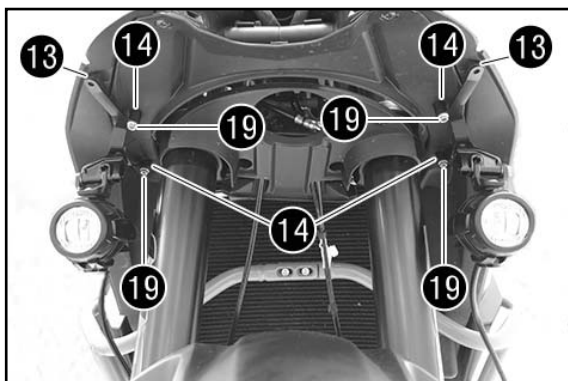

- Posicionar los retenedores con los faros antiniebla a la izquierda 11 y a la derecha 12.
- Montar los casquillos cortos 13 (volumen de suministro).
- Montar los tornillos 19 con los casquillos largos 14 (todo incluido en el volumen de suministro) y apretarlos a 3,5 Nm.

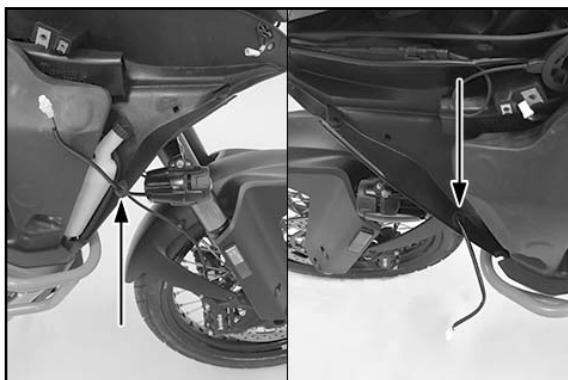

- A ambos lados de la motocicleta, pasar el cable del faro antiniebla a través de los manguitos para cables.

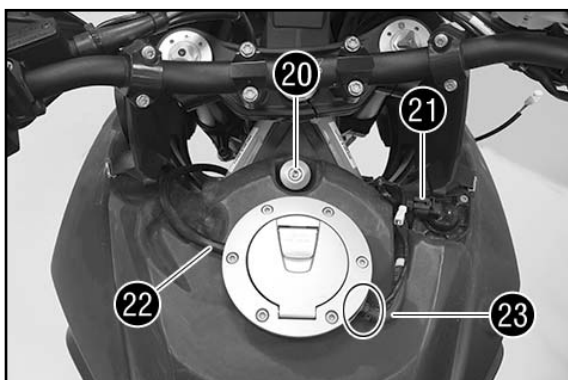

Tendido del ramal de cables

- Retirar el tornillo 20 con el manguito de apoyo y los casquillos de goma.
- Desenchufar el conector 21.
- Retirar el tubo respiradero 22.
- Retirar las bridas.
- Retirar el tubo respiradero 23.



- Retirar los tornillos 24 con los casquillos.
- Levantar ligeramente el depósito y extraerlo hacia atrás.

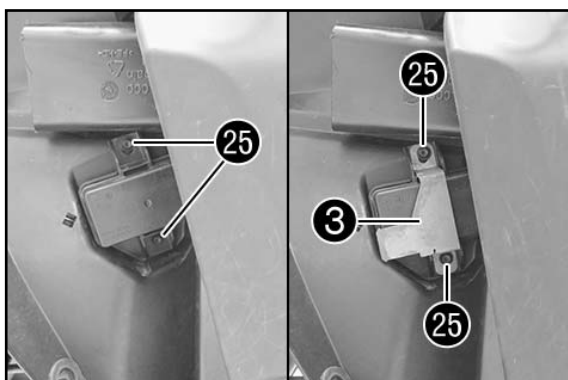

- Retirar los tornillos 25.
- Montar el retenedor con los tornillos 3 (volumen de suministro) con los tornillos 25 y apretar estos.

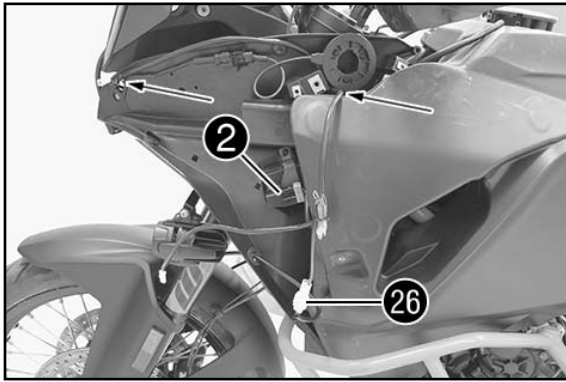

- Tender sin tensiones el ramal de cables (volumen de suministro) hacia el faro tal como se muestra en la figura.
- Montar el relé **2** (volumen de suministro del ramal de cables) en el retenedor **3**.
- Enchufar el conector **26**.

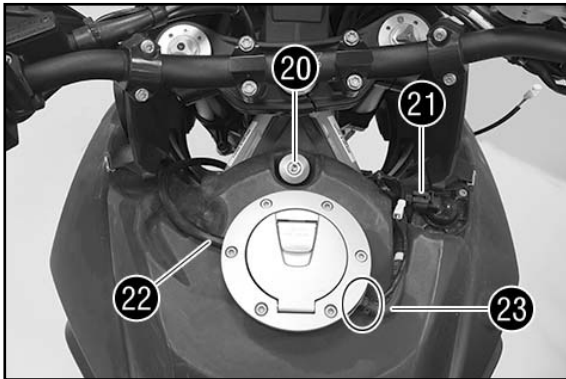

- Colocar el depósito de gasolina.
- Montar el tornillo **20** con el manguito de apoyo y los casquillos de goma, y apretarlo a 15 Nm.
- Enchufar el conector **21**.
- Montar los tubos respiraderos **22** y **23**.
- Montar las bridas.



- Montar a ambos lados los tornillos **24** con los casquillos y apretarlos a 10 Nm.

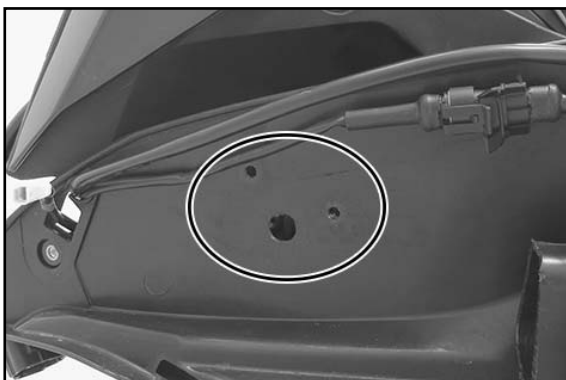

Montaje del interruptor

- Perforar los orificios de montaje (Ø 22 mm y Ø 5 mm) con la herramienta adecuada.

ADVERTENCIA

Las posiciones están marcadas en el carenado.

! AVISO

Durante la perforación, tener cuidado de que ningún componente sufra daños.

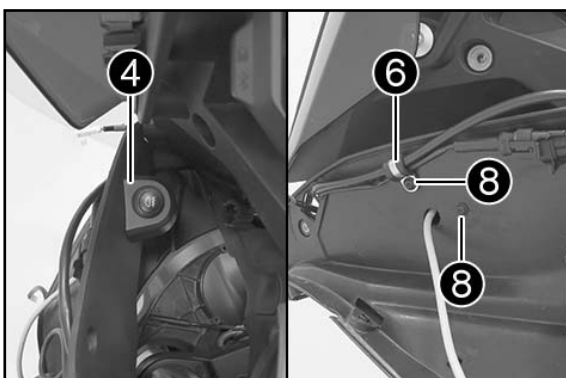

- Posicionar la carcasa del interruptor **4** con el interruptor (volumen de suministro).
- Pasar el cable por el orificio.

- Colocar la abrazadera **6** (volumen de suministro).
- Montar y apretar los tornillos **8** (volumen de suministro).



- Enchufar el conector 27.
- Tender el cable sin tensiones.

! AVISO

Asegurarse de que los cables no puedan retorcerse o quedar aprisionados.

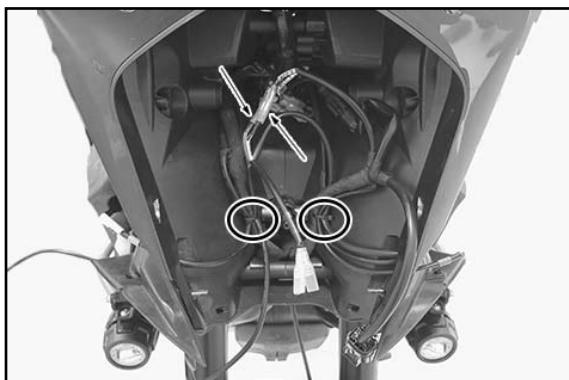

- Conectar el ramal de cables 2 con el ACC2 del ramal de cables del vehículo.

ADVERTENCIA

Los cables tienen un adhesivo con el texto ACC 2.

- Tender el cable sin tensiones y asegurarlo con bridas (volumen de suministro).

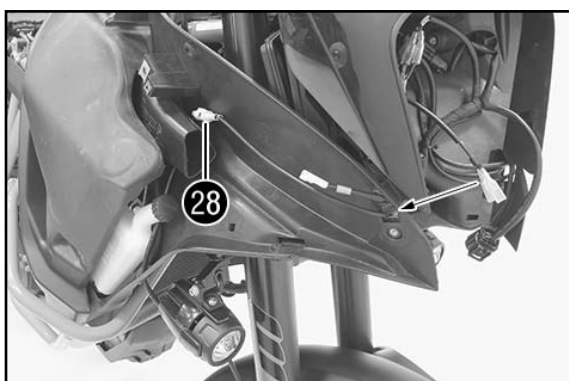

- Tender el cable para el faro antiniebla derecho tal como se muestra en la figura.
- Enchufar el conector 28.

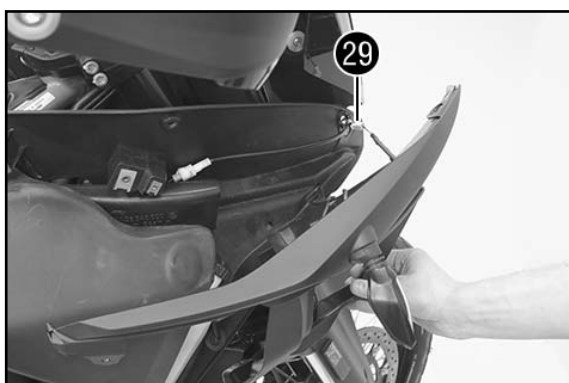

Montaje del spoiler del soporte del faro

- Posicionar el spoiler del soporte del faro derecho.
- Enchufar el conector 29.

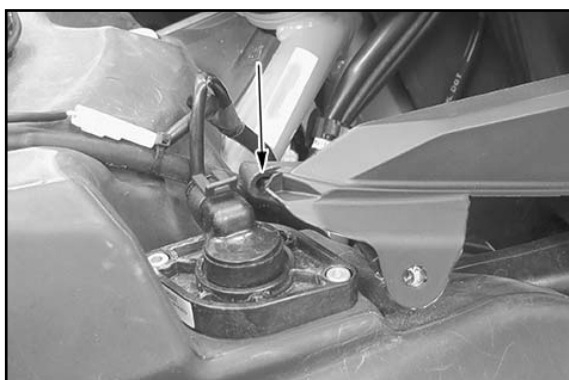

- Colocar el talón de sujeción en el orificio y presionar el spoiler del soporte del faro introduciéndolo en los alojamientos.

ADVERTENCIA

Prestar atención al tendido correcto del cable del intermitente. Prestar atención a que el esnórquel de aspiración esté asentado correctamente.

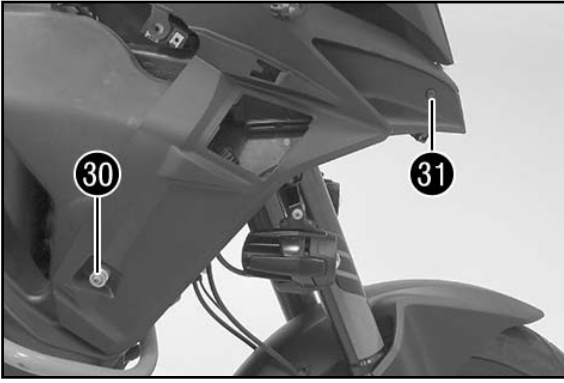

- Montar el tornillo 30 con el casquillo y apretarlo a 4 Nm.
- Montar el tornillo 31 y apretarlo a 3,5 Nm.



- Montar el tornillo 32 y apretarlo a 3,5 Nm.
- Repetir las mismas operaciones en el lado izquierdo.

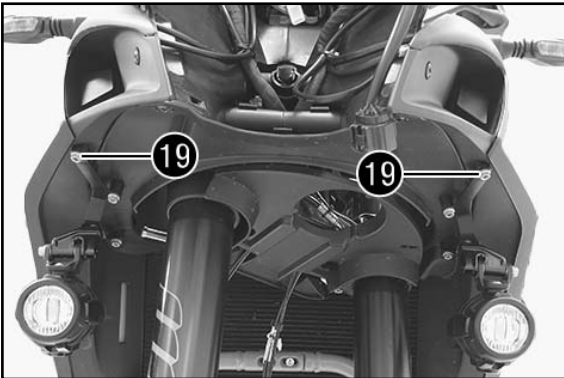

- Montar los tornillos 19 y apretarlos a 3,5 Nm.

Trabajos posteriores

- Montar el faro (véase el manual de reparación).
- Montar el carenado del depósito (véase el manual de instrucciones).
- Montar el carenado lateral delantero (véase el manual de instrucciones).
- Montar el asiento (véase el manual de instrucciones).